

# HEAVY-DUTY SQUARE GLASS CLAMP

135° Glass-to-Glass Square Profile

ITEM NO. CSU135

## SPECIFICATIONS

**Glass Sizes:** 3/8" to 1/2" (10 to 12 mm) Tempered Glass Only

**Construction:** Solid Brass

**Cutout Required:** Cutout No. CSU135

**Includes:** Clamp body, glazing gaskets, mounting screws, and fabrication template.

**Use:** Residential Bath and Commercial Hotel Applications

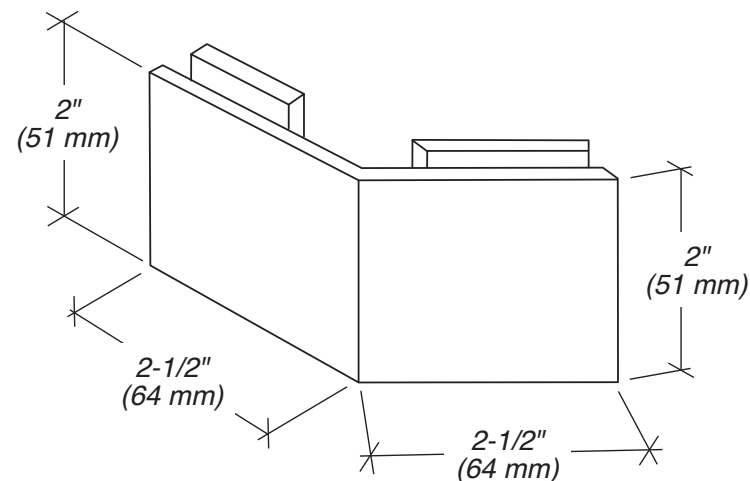

Front View

## GASKET SPECIFICATIONS:

**For 3/8" (10mm) Glass:** Use One Gasket On Each Side

**For 1/2" (12mm) Glass:** Use One Gasket On Each Side

## GLASS INSTRUCTIONS:

Only use tempered safety glass. To prevent damage to the clamp finish during installation, do not use power tools when installing these clamps.

## CARE & CLEANING GUIDELINES:

For best results, keep the following recommendations in mind when caring for your FHC shower door hardware. Your shower door hardware should be dried daily with a soft towel or cloth to insure its original finish. Do not use harsh cleaners or chemicals on the hardware, as many of the components are coated with a clear lacquer that will become damaged beyond repair. Always test your cleaning solution in an inconspicuous area prior to cleaning the entire hardware surface. Wipe surfaces clean using a soft dampened cloth or sponge and rinse completely with warm water immediately after applying the cleaning solution. Use only small amounts of liquid, gentle cleaner. Never use abrasive products, sponges, or wire scrub brushes while cleaning hardware.

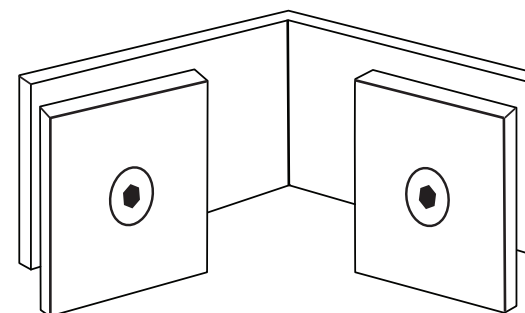

Rear View

# HEAVY-DUTY SQUARE GLASS CLAMP

135° Glass-to-Glass Square Profile  
ITEM NO. CSU135



DO NOT MEASURE / SCALE DRAWING  
USE DIMENSIONS SHOWN

Cutout No. CSU135

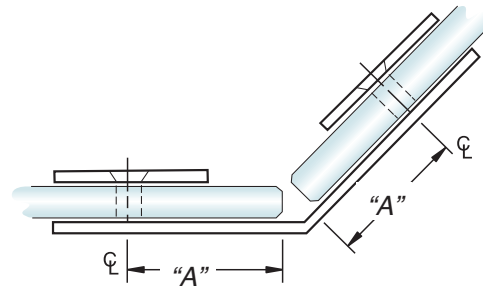

GLASS THICKNESS	"A" MEASUREMENT
3/8" (10 mm)	1-5/16" (33 mm)
1/2" (12 mm)	1-1/4" (32 mm)

## TEMPLATE OPTION FOR SQUARE CUT GLASS

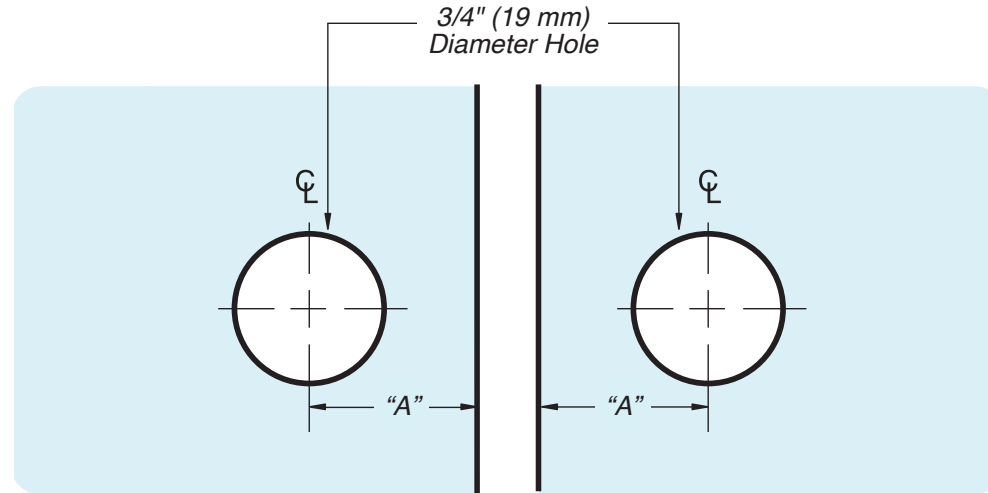

## TEMPLATE OPTION FOR 22-1/2° MITERED GLASS (TYPICAL INSTALLATION)

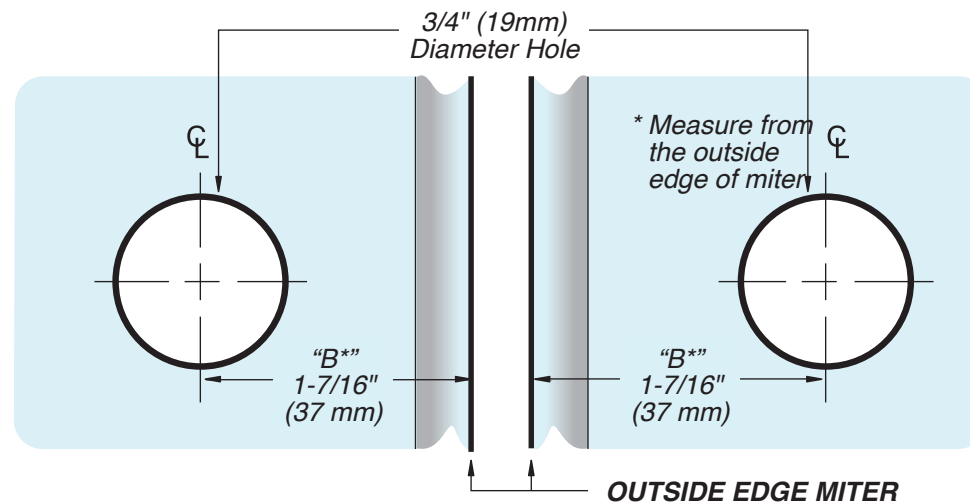
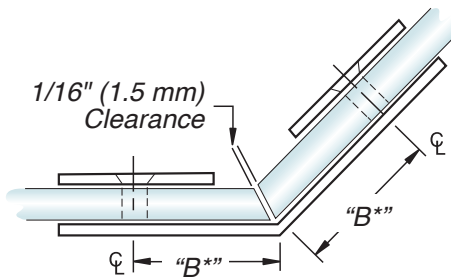

USE ONLY MONOLITHIC TEMPERED GLASS



For Technical Support  
Call Toll Free in the U.S.  
(888) 295-4531

