

FHC ACHIEVE FRAMELESS GLASS RAILINGS



FHC A1M Series

1/2" (12 mm) - 9/16" (13.52mm) Glass Railing Base Shoe

- Innovative Design Maintains Railing Industry Standard 4-1/8" Base Shoe Height
- Compatible With 1/2" Monolithic and 9/16" Laminated Tempered Glass Applications
- New Design - 40% Lighter Than Traditional Base Shoes
- 20' Stock Lengths Drilled or Undrilled
- Designed for Heavy Glass Railing and

- Windscreen Applications
- Custom Fabrication Services Available
- 6063-T5 Aluminum Alloy
- FHC's Innovative "One Seal" 1SGA Series Gasket Makes Installations Easy. Installers Can Pre-Load Gasket Before Setting Glass and Use the Same Gasket on he Inside to Finish the Installation

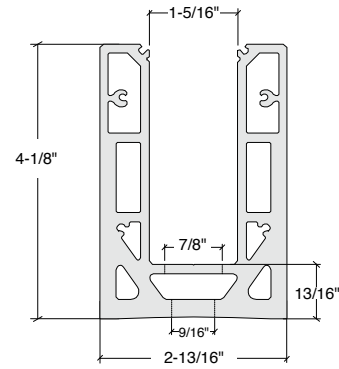
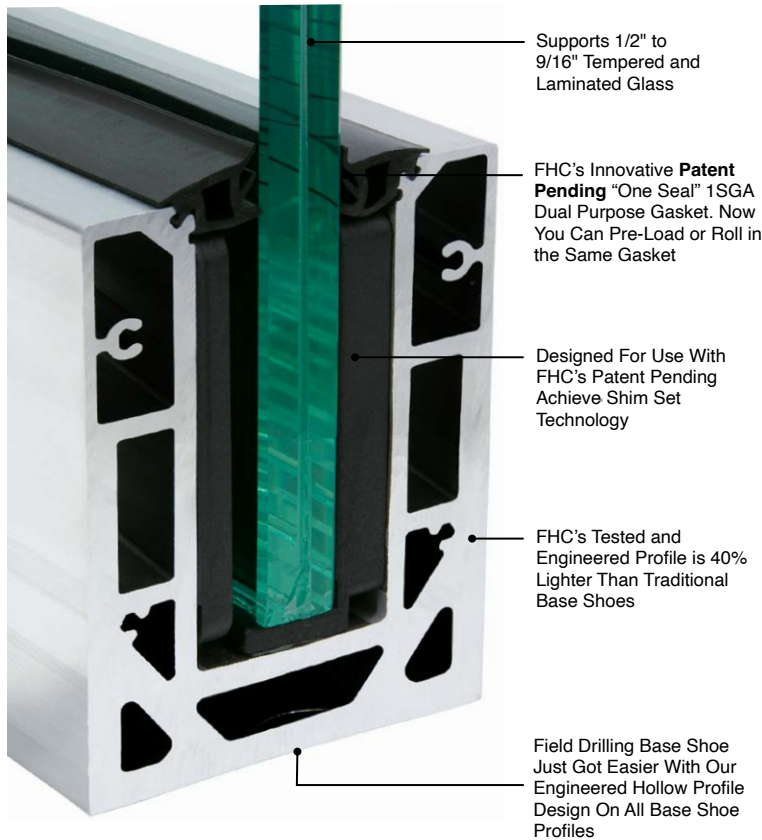

D Profile
Bottom Drilled and Counterbored 12" on Center and 6" From Each End

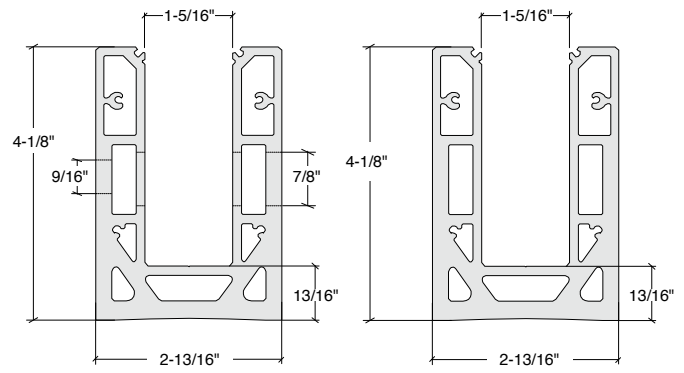

F Profile
Fascia/Side Drilled and Counterbored 12" On Center and 6" From Each End

Undrilled Profile

ACHIEVE INSTALLATION TOOL KIT



Item No. **ACH1K**

ACHIEVE SHIM SETS



Item No. **ACH2G**
FHC Achieve Glass Rail Shim Set
10 Shim's Sets Per Box

WITHOUT LOCK ITEM NO.	DESCRIPTION
A1M20	A1M Achieve Series Aluminum Base Shoe Undrilled 240" Long
A1M20D	A1M Achieve Series Aluminum Base Shoe Bottom Drilled 12" C.T.C. 240" Long
A1M20F	A1M Achieve Series Aluminum Base Shoe Fascia Drilled 12" C.T.C. 240" Long
A1M10	A1M Achieve Series Aluminum Base Shoe Undrilled 120" Long
A1M10D	A1M Achieve Series Aluminum Base Shoe Bottom Drilled 12" C.T.C. 120" Long
A1M10F	A1M Achieve Series Aluminum Base Shoe Fascia Drilled 12" C.T.C. 120" Long

Must Ship common carrier.

FHC ACHIEVE®
One Seal Gasket

ITEM NO.	ROLL LENGTH
1SGA250	250'
1SGA500	500'

Minimum order: 1 Roll.



SUPPORTS LAMINATED TEMPERED GLASS

OR



SUPPORTS MONOLITHIC TEMPERED GLASS



For Technical Support
Call Toll Free in the U.S.
(888) 295-4531

EXPERIENCE AND INNOVATION

