

FHC Compact 161 Series Single Sliding Door Kit

Top Hung Single Sliding Door With Fixed Panel Kit Wall or Ceiling Mount

- Single Door With Fixed Panel Slider Kit
- Wall or Ceiling Mount
- For 3/8", 1/2", and 9/16" Glass
- Compact Profile Available in Two Finishes, Satin Anodized and Matte Black
- Glass Fabrication Not Required
- Ball Bearing Rollers for a Smooth Slide
- Max. Door Weight is 350 lbs.
- Max. Door Weight is 265 lbs. When Used With Soft Close Option
- Includes Channel and Vinyls for Fixed Panel

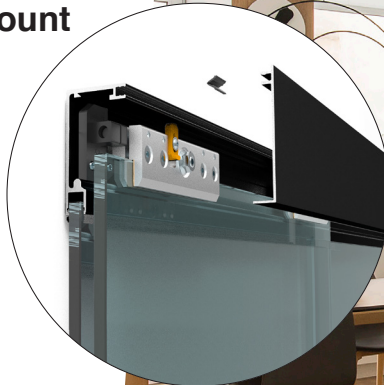

CSI DIVISION 08
SECTION
08 3200



Use Monolithic Tempered Glass

OR



Use Laminated Tempered Glass

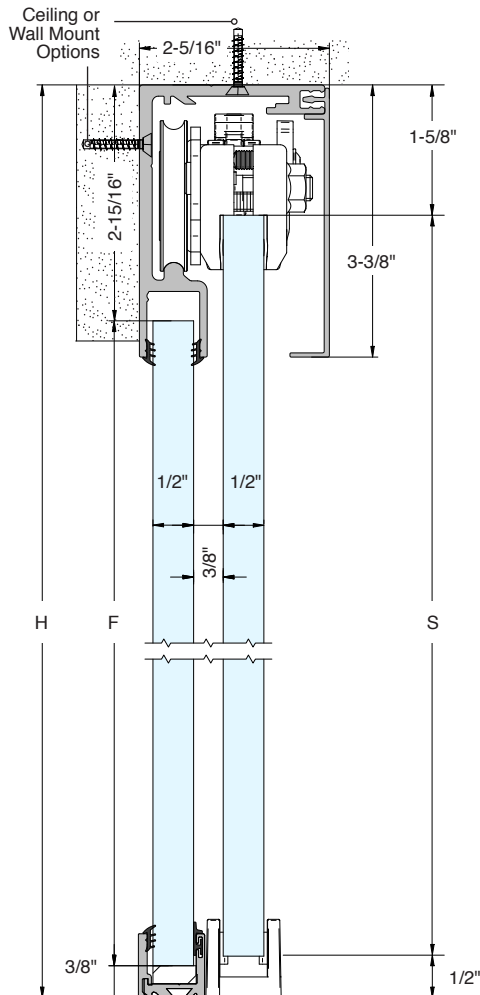

Fixed Panel (F) Glass Deducts = Height (H) Minus 3-5/16"
Slider Panel (S) Glass Deducts = Height (H) Minus 2-1/8"

FHC COMPACT 161 SINGLE SLIDING DOOR KIT WITH SOFT CLOSE AND FIX PANEL KIT

ITEM NO.	DESCRIPTION	FINISH
COM161SA	Wall or Ceiling Mount Single Door Slider With Fixed Panel	Satin Anodized
COM161MB	Wall or Ceiling Mount Single Door Slider With Fixed Panel	Matte Black

Kits Include: 118" (3 m) stock lengths and must ship common carrier.

Kits Include the Following Components:

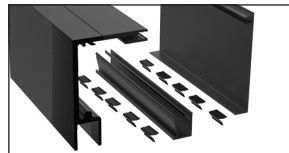

ITEM NO. **COM160EXT**
One Top Track, One Top Track Cover, and One Snap-In Channel Filler, all in 118" in Length

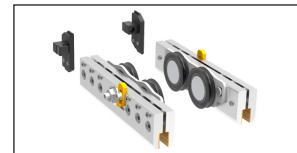

ITEM NO. **COM160RLRS**
Two Hanger/Roller Assemblies, and Two Stops



ITEM NO. **COM161BTM**
Bottom Channel for Fixed Lite
78-3/4" in Length Vinyl Included



ITEM NO. **COM160GD**
One Bottom Floor Guide



ITEM NO. **COM160SFTCLS**
One Soft Close, Six Activators With Three Different Heights



ITEM NO. **COM160EC**
Two Top Track End Caps

Available Finishes



SATIN ANODIZED



MATTE BLACK



For Technical Support
Call Toll Free in the U.S.
(888) 295-4531

EXPERIENCE AND INNOVATION



P.O. Box 1906, South Gate, CA 90280 Toll Free: (888) 295-4531 | Fax: (323) 336-8307 | Web: fhc-usa.com