

FHC GLASS CLAMPS

FHC Adjustable Wall Mount Clamps

For Fixed Panels

ITEM NO. CADJ037

ITEM NO. CADJSQ037

ITEM NO. CADJBV037

SPECIFICATIONS

Glass Sizes: 5/16" (8mm) to 1/2" (12 mm) Tempered Glass Only

Construction: Solid Brass

Includes: Clamp body, glazing gaskets, wall mounting screws

Use: Residential Bath and Commercial Hotel Applications

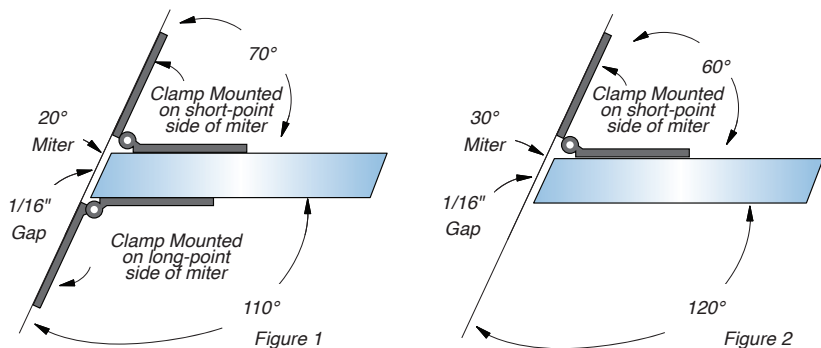

HOLE DRILLING GUIDELINE:

The Chart on the right addresses the dimension required from the long-point of the miter to the centerline of a 7/8" (22 mm) hole in the glass. No U-notches are required for the CADJ037, All dimensions shown already allow for a 1/16" (1.5 mm) clearance between the glass and the wall.

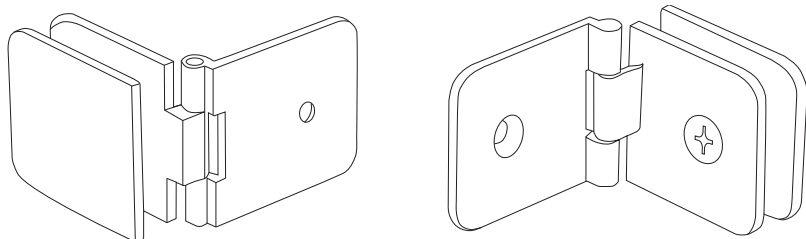

FRONT VIEW

BACK VIEW

ANGLE	DIMENSIONS FROM LONG POINT OF MITER TO CENTER OF 7/8" (22 mm) DIAMETER	
	Mount to Wall on Short-Point of Miter	Mount to Wall on Long-Point of Miter
0 - 5 Degrees	1-1/2" (38 mm)	1-1/2" (38 mm)
6 - 10 Degrees	1-9/16" (40 mm)	1-7/16" (37 mm)
11 - 15 Degrees	1-5/8" (41 mm)	1-7/16" (37 mm)
16 - 20 Degrees	1-11/16" (43 mm)	1-3/8" (35 mm)
21 - 25 Degrees	1-3/4" (44 mm)	1-3/8" (35 mm)
26 - 30 Degrees	1-7/8" (48 mm)	N/A
31 - 35 Degrees	1-15/16" (49 mm)	N/A
36 - 40 Degrees	2-1/16" (52 mm)	N/A
41 - 45 Degrees	2-3/16" (56 mm)	N/A
46 - 47 Degrees	2-5/16" (59 mm)	N/A
48 - 50 Degrees	2-7/16" (62 mm)	N/A

NOTE: All dimensions above already provide for A 1/16" (1.5 mm) Clearance between the two pieces of glass.

DETERMINING ANGLE AND MITER:

In order to use the CADJ037, the angle at which the glass runs into the wall must be properly identified. Please use the following as a guideline to correctly identify the angle and miter required: When a fixed panel of glass runs into a wall squarely at 90 degrees, the angle/miter is considered "0". "0" means "no miter" on the glass. If a glass panel runs into a wall at an angle, a miter should be put on the glass to correspond with the number of degrees from 90 (or "0" miter) the glass is to be mitered. In Figure 1 on the left, the glass is running into the wall at 110°/70°. Each of these numbers is 20° from 90°. As shown in Figure 1, a 20° miter is put on the glass. To get the correct hole location in the glass, use the chart above.

The CADJ037 Adjustable Wall-to-Glass Clamps is designed for use in fastening a fixed panel of glass that runs into a wall at an angle other than 90 degrees. It is important to note the clamp can be mounted to the wall on either the long-point side or short-point side of the miter, on angles up to 25 degrees (not lower than 65 degrees or over 115 degrees). For angles more then 25 degrees from 90 degrees (lower than 65 degrees or over 115 degrees), the wall-mounted portion must be fastened on the side of the glass that has the short-point of the miter (see Figure 2).

