

# CAMBRIA

## Top and Bottom Pivot Hinge with Rear Drip Plate

### ITEM NO. CAM08

Edge Pivot Preferred Option with 7/16" (11 mm)

Top and Bottom Clearance

#### SPECIFICATIONS

**Glass Sizes:** 3/8" (10 mm) Tempered Glass Only  
**Construction:** Solid Brass  
**Closing Type:** Self-Centering When Within 15 Degrees of Closed Position  
**Cutout Required:** Cutout No. SD7, SD8, SD9, SD10, SD11 or SD12  
**Includes:** Hinge body, glazing gaskets, wall mounting screws, allen head/phillips head cover plate screws, and fabrication template.  
**Use:** Residential Bath and Commercial Hotel Applications

#### GASKET SPECIFICATIONS:

**For 3/8" (10mm) Glass:** Use One Thin Gasket On One Side and One Thick Gasket on the Other Side

#### GLASS INSTRUCTIONS:

Only use tempered safety glass. To prevent damage to the hinge finish during installation, do not use power tools when installing these hinges.

#### IMPORTANT INFORMATION:

The Cambria Series Pivot Hinge offers advantages over a standard shower door hinge. One benefit is that you can adjust your hinge "pivot point" giving additional clearance for pull handles, towel bars, or wall conditions that could interfere when the door is opened 90 degrees. Additionally, the pivot hinge design allows most of the door's weight to primarily rest on the bottom pivot fitting, giving more stability and a reduced load. Pivot hinge comes factory set at a standard closed position, an optional 5 degree pivot pin set (Item # P1VPN38) is also available and can be installed on the jobsite. This option allows an additional 5 degrees of closing for jobs that require a firmer, positive position against a jamb or seal.

#### MAXIMUM CAPACITY:

MAXIMUM DOOR CAPACITY	3/8" (10 mm) GLASS Approx. 5 lb/ft <sup>2</sup>	
	DOOR WEIGHT	DOOR WIDTH
USING 2 HINGES	100 LBS. (66 kg)	31" (787 mm)

NOTE: Do not exceed either maximum weight or width when choosing proper quantity of hinges.

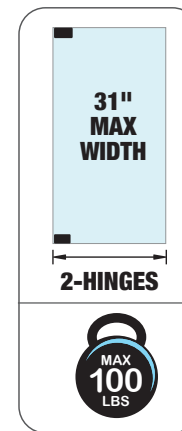
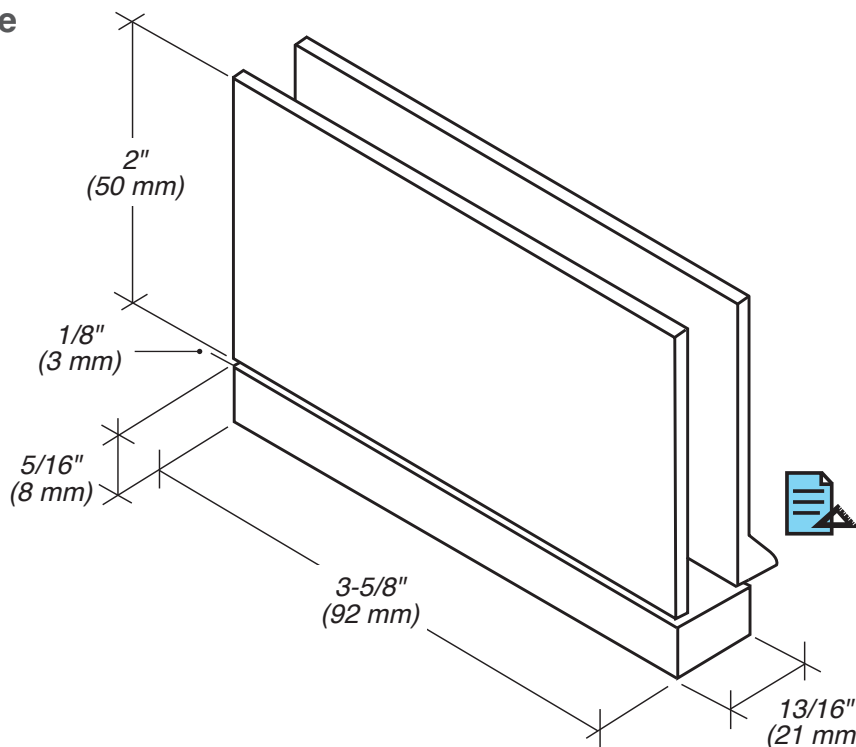

**SEE TEMPLATE ON BACK**  
Refer to Dimensions Shown to Ensure Accuracy

#### CARE & CLEANING GUIDELINES:

For best results, keep the following recommendations in mind when caring for your FHC shower door hardware. Your shower door should be dried daily with a soft towel or cloth to ensure its original finish. Do not use harsh cleaners or chemicals on the hardware, as many of the components are coated with a clear lacquer that will become damaged beyond repair. Always test your cleaning solution in an inconspicuous area prior to cleaning the entire hardware surface. Wipe surfaces clean using a soft, dampened cloth or sponge, and rinse completely with warm water immediately after applying the cleaning solution. Use only small amounts of liquid, gentle, cleaner. Never use abrasive products, sponges, or wire scrub brushes while cleaning hardware.

#### MAINTENANCE:

FHC's hinges come factory greased for a silent, hassle-free experience. If there is any noticeable squeaking that occurs after installation it is recommended to apply a few drops of (3 in 1) multi-purpose oil to the hinge, at the nylon washer/pivot location. The lubricant will penetrate the hinge crevices, reducing friction, cleaning grime, and/or buildup. Spray lubricants are prohibited. If, for some reason, the hinge is disassembled during maintenance, use a small amount of white lithium grease to lubricate the interior hinge components.



# CAMBRIA

## Top and Bottom Pivot Hinge with Rear Drip Plate

### ITEM NO. CAM08

Edge Pivot Preferred Option with 7/16" (11 mm)

Top and Bottom Clearance



DO NOT MEASURE / SCALE DRAWING  
USE DIMENSIONS SHOWN

Cutout No. SD10

\*\* Disregard Top Clearance shown if using FHC's Header Kit.

### EDGE PIVOT PREFERRED OPTION WITH 7/16" (11 MM) TOP AND BOTTOM CLEARANCE

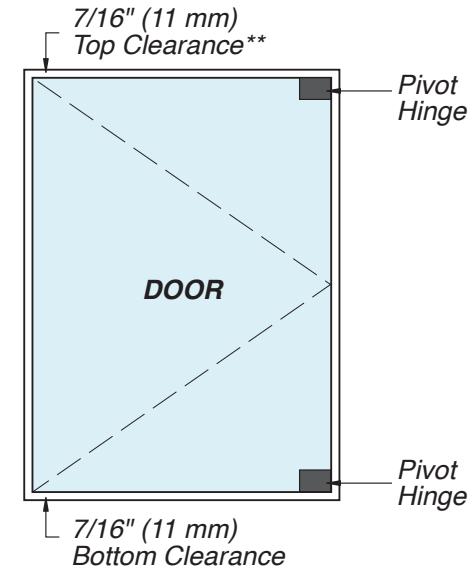
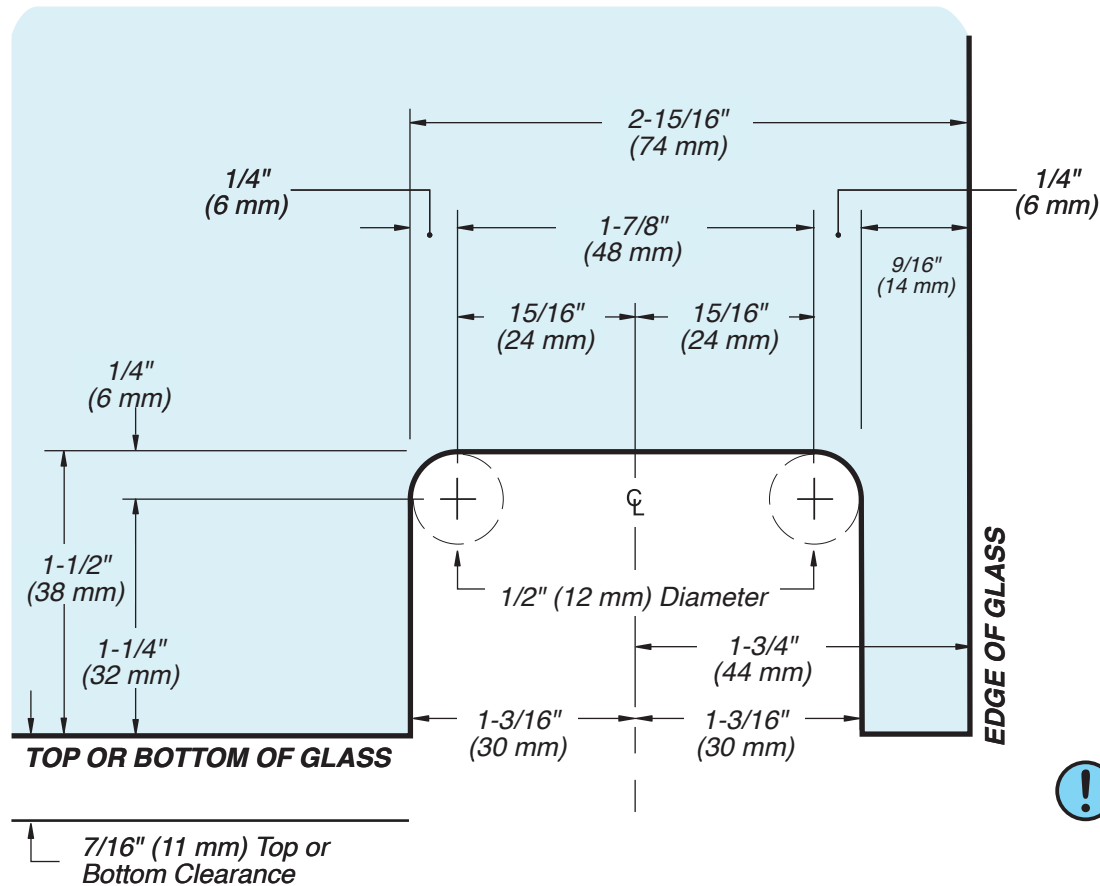

**IMPORTANT:**  
Measure from Finished  
Edge of Glass



# CAMBRIA

## Top and Bottom Pivot Hinge with Rear Drip Plate

### ITEM NO. CAM08

Edge Pivot Preferred Option with 7/16" (11 mm)

Top and Bottom Clearance



DO NOT MEASURE / SCALE DRAWING  
USE DIMENSIONS SHOWN

Cutout No. SD11

\*\* Disregard Top Clearance shown if using FHC's Header Kit.

### EDGE PIVOT PREFERRED OPTION WITH 7/16" (11 MM) TOP AND BOTTOM CLEARANCE

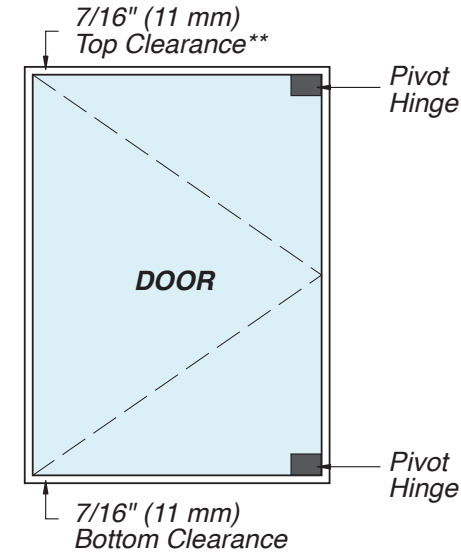
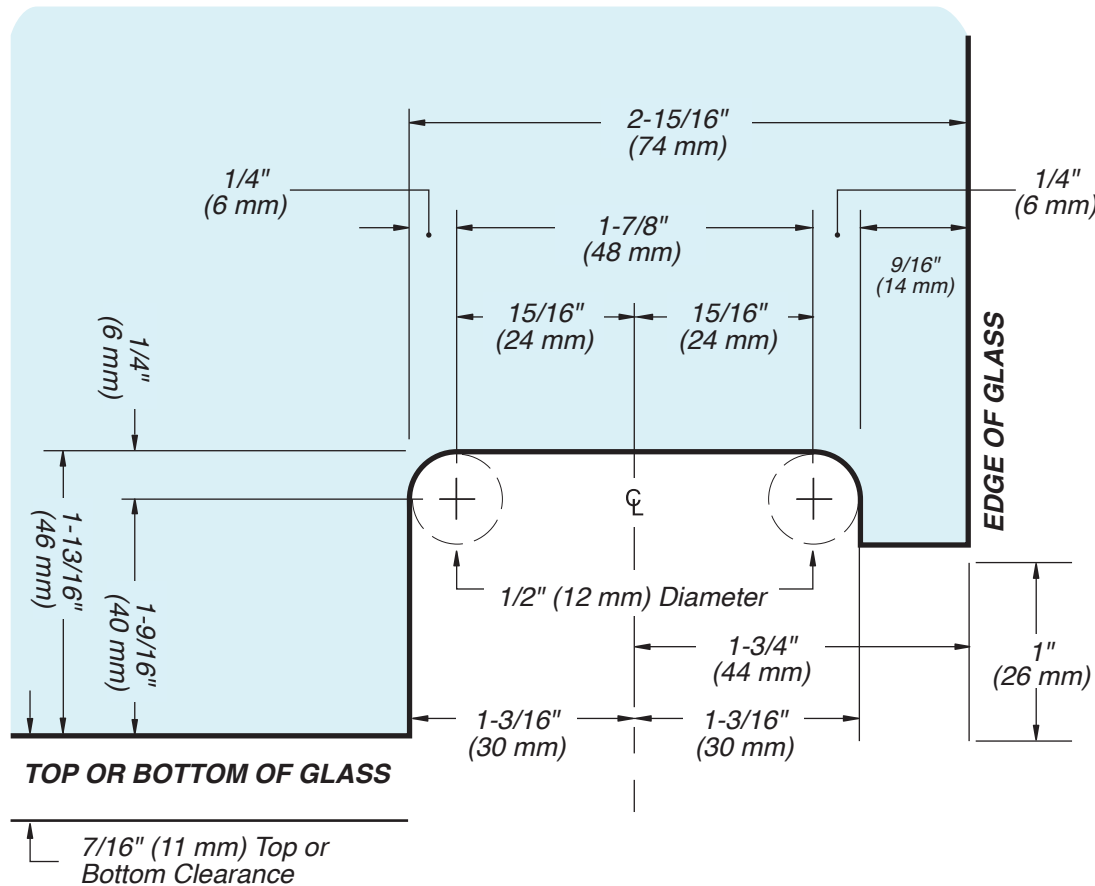

**IMPORTANT:**  
Measure from Finished  
Edge of Glass



USE ONLY  
MONOLITHIC  
TEMPERED GLASS



For Technical Support  
Call Toll Free in the U.S.  
**(888) 295-4531**



# CAMBRIA

## Top and Bottom Pivot Hinge with Rear Drip Plate

### ITEM NO. CAM08

Edge Pivot Preferred Option with 1/8" (3 mm)

Top and Bottom Clearance

### EDGE PIVOT ALTERNATE OPTION WITH 1/8" (3 MM) TOP AND BOTTOM CLEARANCE

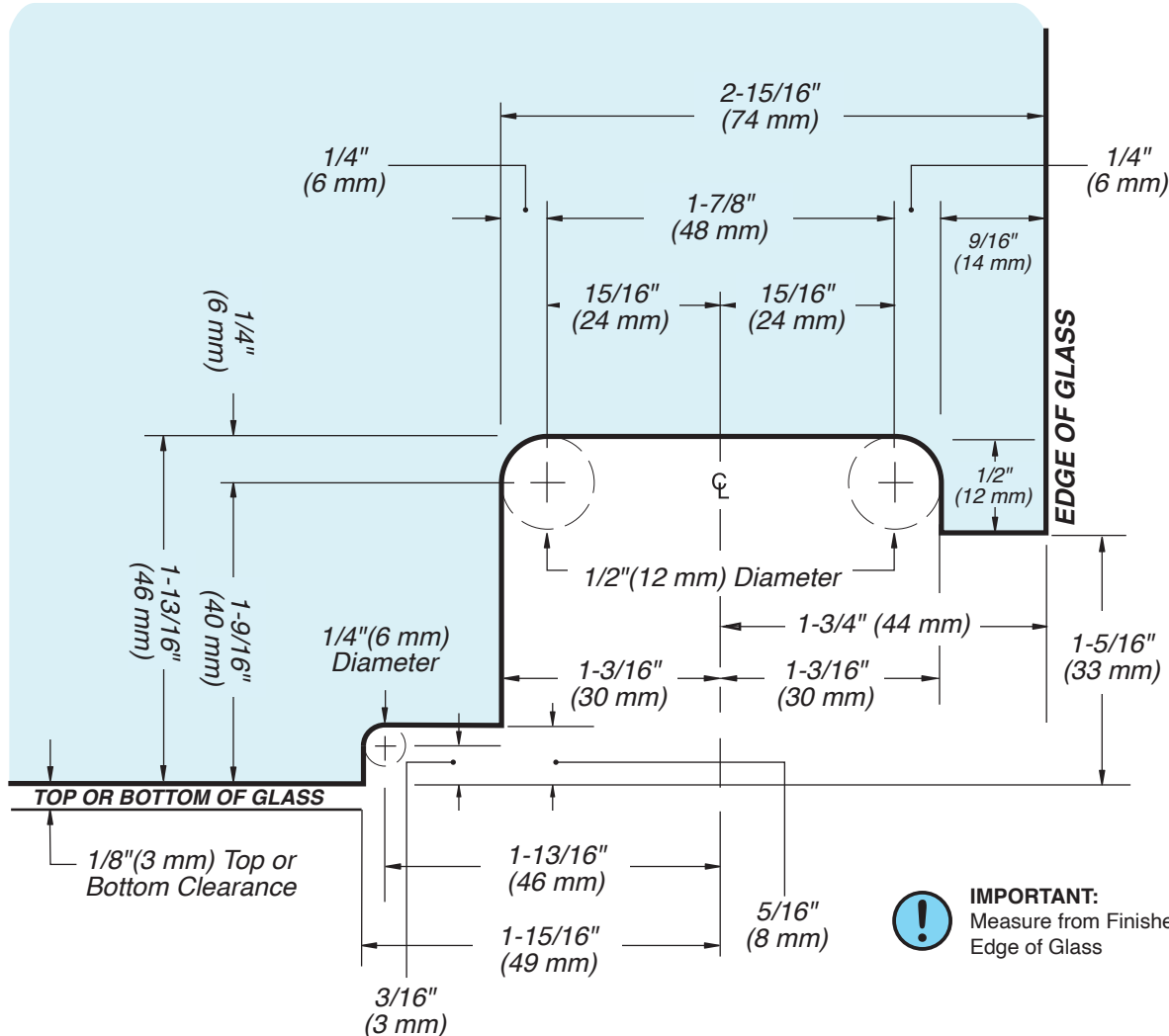

DO NOT MEASURE / SCALE DRAWING  
USE DIMENSIONS SHOWN



Cutout No. SD9

\*\* Disregard Top Clearance shown if using FHC's Header Kit.

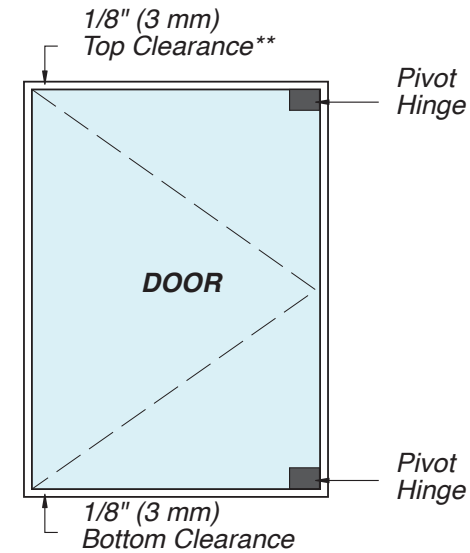

USE ONLY  
MONOLITHIC  
TEMPERED GLASS



For Technical Support  
Call Toll Free in the U.S.  
**(888) 295-4531**

**FHC**  
FRAMELESS HARDWARE COMPANY  
THE GLAZING SUPPLY COMPANY  
EXPERIENCE AND INNOVATION

# CAMBRIA

## Top and Bottom Pivot Hinge with Rear Drip Plate

### ITEM NO. CAM08

Edge Pivot Preferred Option with 3/16" (5 mm)

Top and Bottom Clearance

### EDGE PIVOT ALTERNATE OPTION WITH 3/16" (5 MM)

### TOP AND BOTTOM CLEARANCE

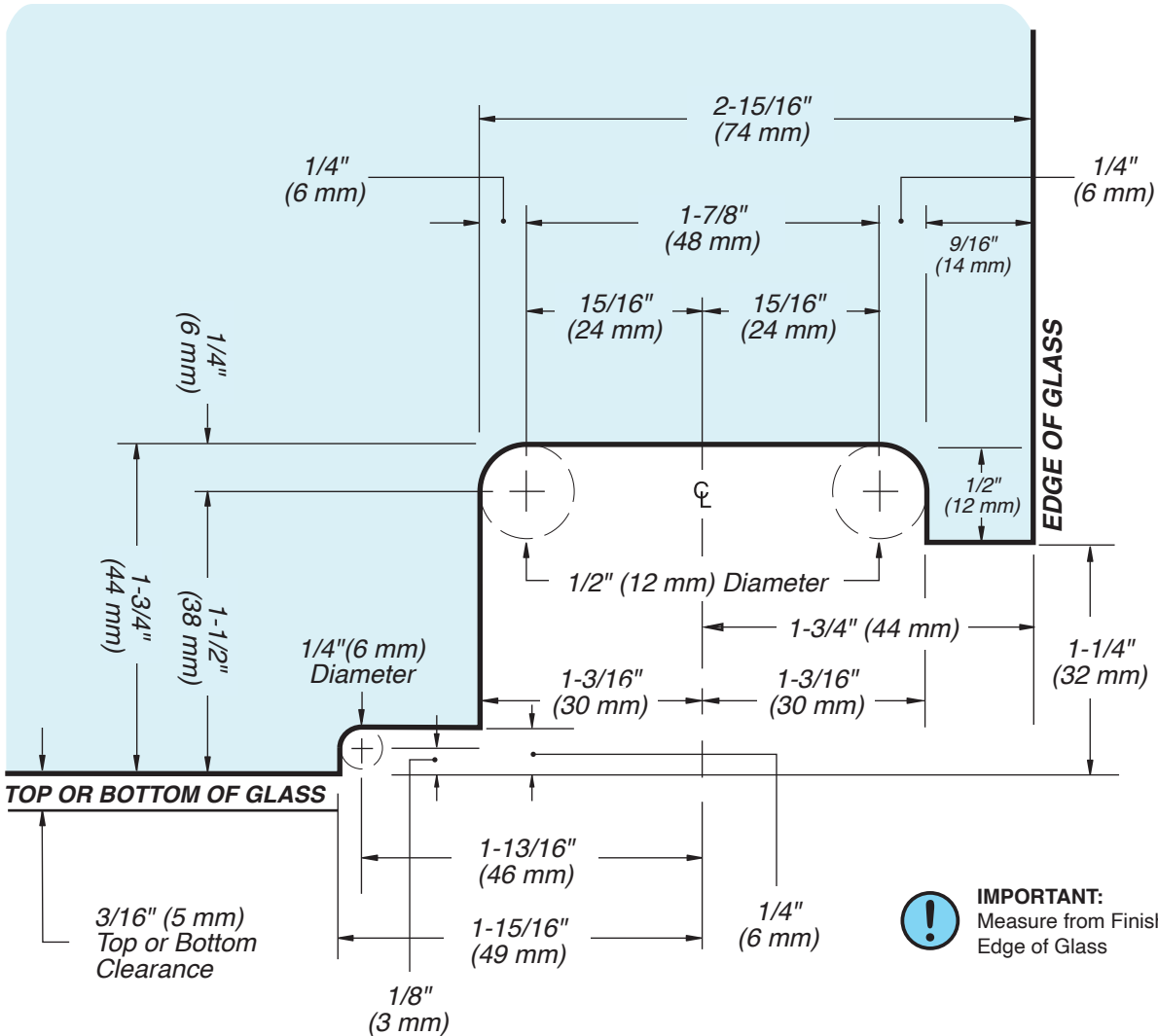

**IMPORTANT:**  
Measure from Finished  
Edge of Glass

DO NOT MEASURE / SCALE DRAWING  
USE DIMENSIONS SHOWN



Cutout No. SD8

\*\* Disregard Top  
Clearance shown  
if using FHC's  
Header Kit.

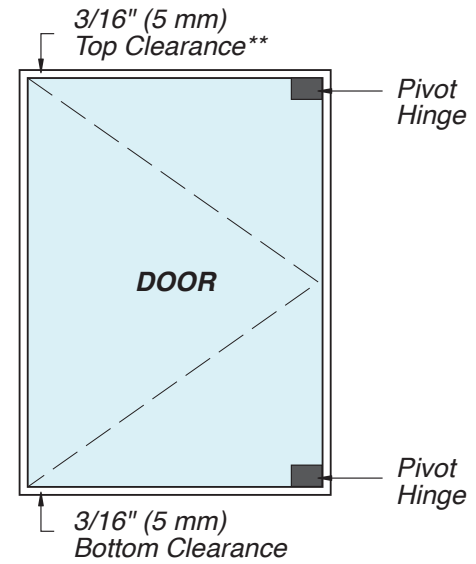

**USE ONLY  
MONOLITHIC  
TEMPERED GLASS**



For Technical Support  
Call Toll Free in the U.S.  
**(888) 295-4531**

**FHC**  
FRAMELESS HARDWARE COMPANY  
THE GLAZING SUPPLY COMPANY  
EXPERIENCE AND INNOVATION

# CAMBRIA

## Top and Bottom Pivot Hinge with Rear Drip Plate

### ITEM NO. CAM08

Edge Pivot Preferred Option with 7/16" (11 mm)

Top and Bottom Clearance



DO NOT MEASURE / SCALE DRAWING  
USE DIMENSIONS SHOWN

Cutout No. SD07

\*\* Disregard Top Clearance shown if using FHC's Header Kit.

### INSET PIVOT OPTION WITH 7/16" (11 MM) TOP AND BOTTOM CLEARANCE

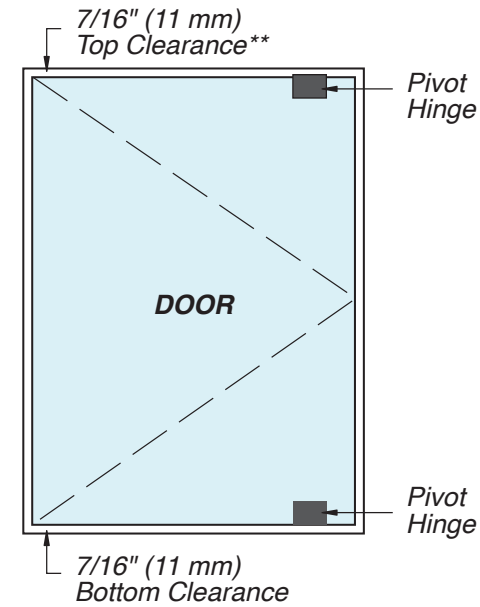
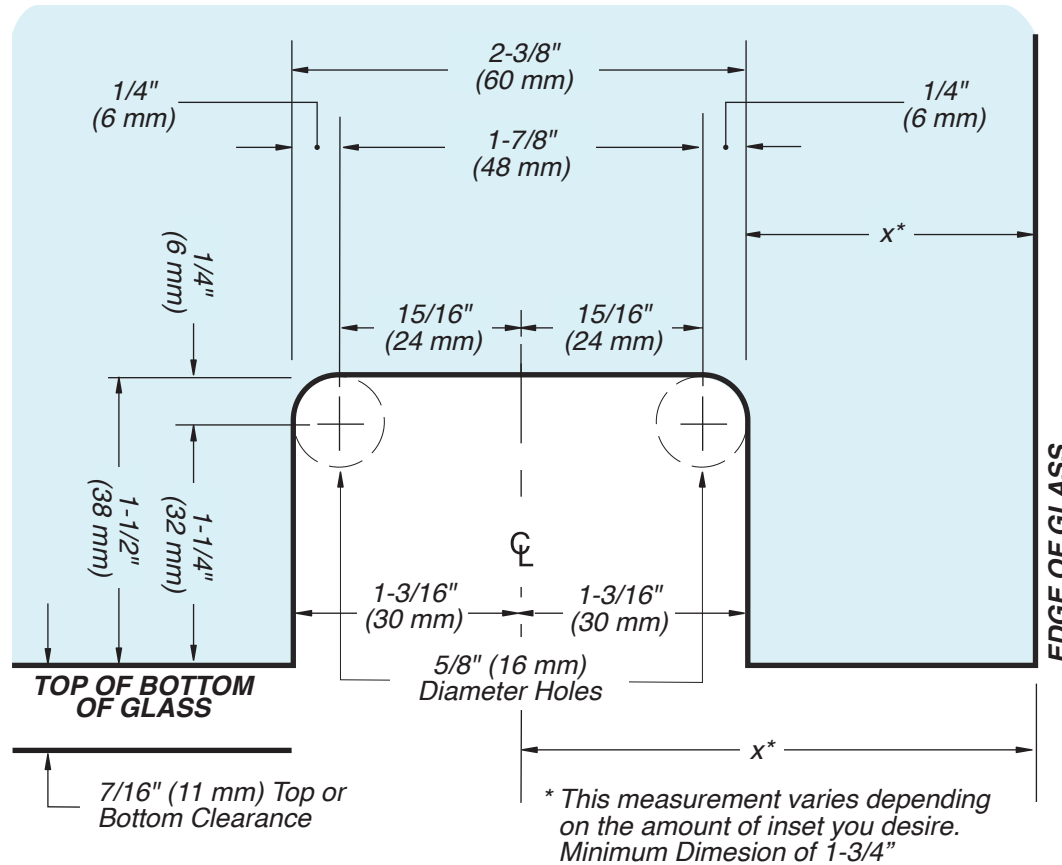

USE ONLY MONOLITHIC TEMPERED GLASS

**IMPORTANT:** Measure from Finished Edge of Glass



For Technical Support Call Toll Free in the U.S. (888) 295-4531

