

OPEN FACE BEVELED GLASS CLAMP

90° Glass-to-Glass Beveled Profile

ITEM NO. CBU0F90

SPECIFICATIONS

Glass Sizes: 3/8" to 1/2" (10 to 12 mm) Tempered Glass Only

Construction: Solid Brass

Cutout Required: Cutout No. SD27

Includes: Clamp body, glazing gaskets, mounting screws, and fabrication template.

Use: Residential Bath and Commercial Hotel Applications

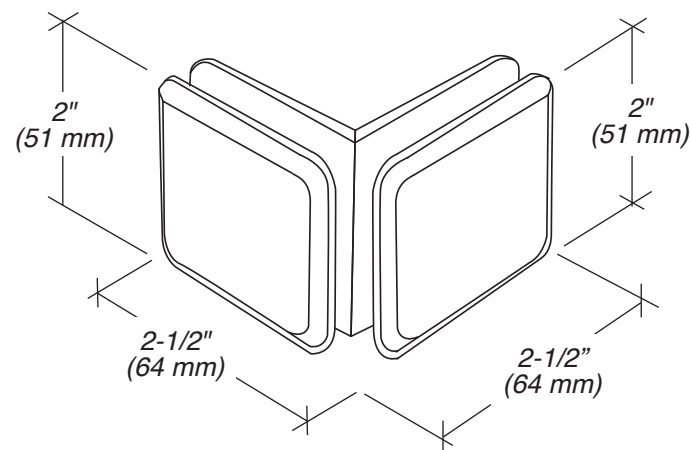

Front View

GASKET SPECIFICATIONS:

For 3/8" (10mm) Glass: Use One Thick Gasket On Each Side

For 1/2" (12mm) Glass: Use One Thin Gasket On Each Side

GLASS INSTRUCTIONS:

Only use tempered safety glass. To prevent damage to the clamp finish during installation, do not use power tools when installing these clamps.

CARE & CLEANING GUIDELINES:

For best results, keep the following recommendations in mind when caring for your FHC shower door hardware. Your shower door hardware should be dried daily with a soft towel or cloth to insure its original finish. Do not use harsh cleaners or chemicals on the hardware, as many of the components are coated with a clear lacquer that will become damaged beyond repair. Always test your cleaning solution in an inconspicuous area prior to cleaning the entire hardware surface. Wipe surfaces clean using a soft dampened cloth or sponge and rinse completely with warm water immediately after applying the cleaning solution. Use only small amounts of liquid, gentle cleaner. Never use abrasive products, sponges, or wire scrub brushes while cleaning hardware.

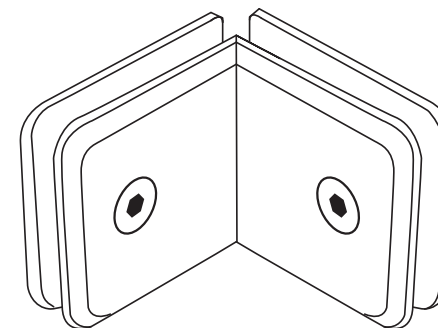

Rear View

OPEN FACE BEVELED GLASS CLAMP

90° Glass-to-Glass Beveled Profile
ITEM NO. CBU0F90



DO NOT MEASURE / SCALE DRAWING
USE DIMENSIONS SHOWN

Cutout No. SD27

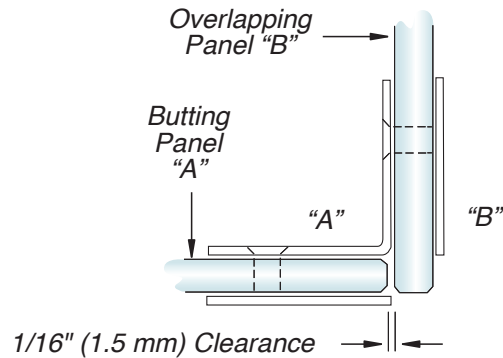

GLASS THICKNESS	"A" MEASUREMENT	"B" MEASUREMENT
3/8" (10 mm)	1-1/8" (29 mm)	1-1/2" (38 mm)
1/2" (12 mm)	1-1/8" (29 mm)	1-5/8" (41 mm)

TEMPLATE OPTION FOR STANDARD FLAT POLISHED SQUARE CUT GLASS

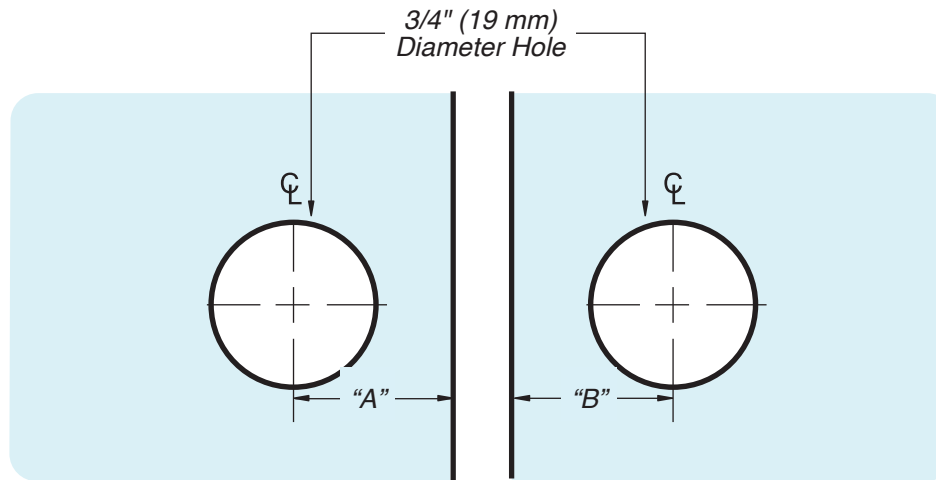

TEMPLATE OPTION FOR 45° MITERED GLASS (TYPICAL INSTALLATION)

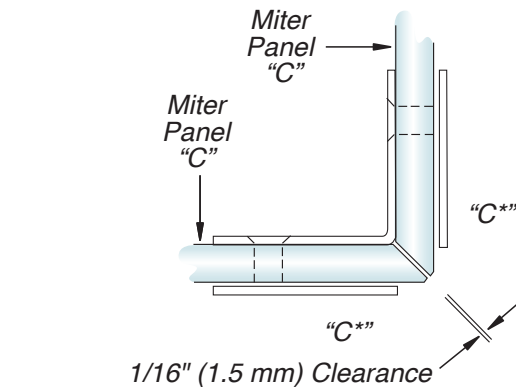

GLASS THICKNESS	"C*" MEASUREMENT
3/8" (10 mm)	1-7/16" (37 mm)
1/2" (12 mm)	1-9/16" (40 mm)

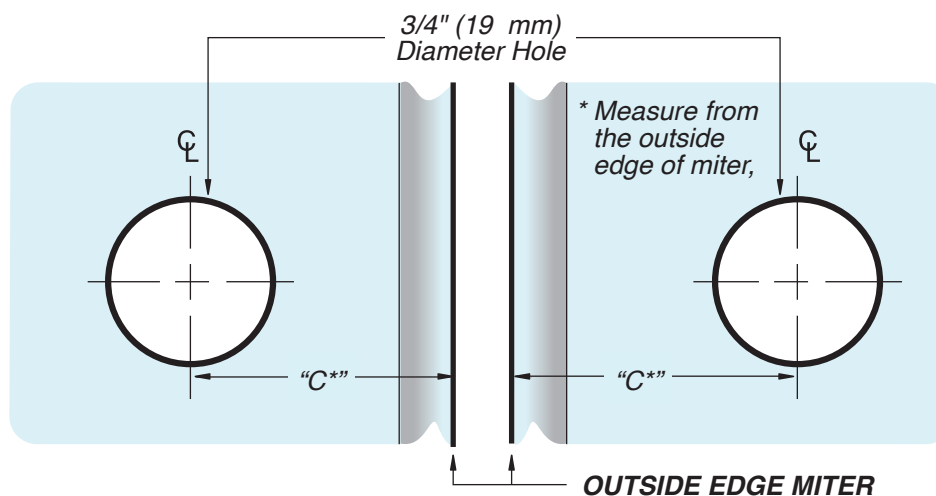

USE ONLY
MONOLITHIC
TEMPERED GLASS



For Technical Support
Call Toll Free in the U.S.
(888) 295-4531

