

HEAVY-DUTY RADIUS CORNERS GLASS CLAMP

180° No Glass Fabrication Square Profile

ITEM NO. CSN180

SPECIFICATIONS

Glass Sizes: 3/8" to 1/2" (10 to 12 mm) Tempered Glass Only

Construction: Solid Brass

Cutout Required: Cutout No.SD30

Includes: Clamp body, glazing gaskets, mounting screws, and fabrication template.

Use: Residential Bath and Commercial Hotel Applications

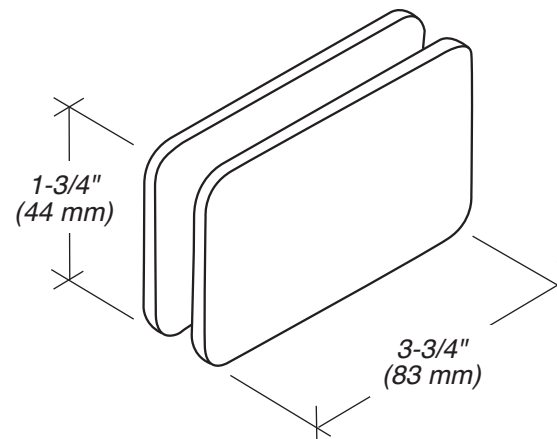

Front View

GASKET SPECIFICATIONS:

For 3/8" (10mm) Glass: Use One Thick Gasket On Each Side

For 1/2" (12mm) Glass: Use One Thin Gasket On Each Side

GLASS INSTRUCTIONS:

Only use tempered safety glass. To prevent damage to the clamp finish during installation, do not use power tools when installing these clamps.

CARE & CLEANING GUIDELINES:

For best results, keep the following recommendations in mind when caring for your FHC shower door hardware. Your shower door hardware should be dried daily with a soft towel or cloth to insure its original finish. Do not use harsh cleaners or chemicals on the hardware, as many of the components are coated with a clear lacquer that will become damaged beyond repair. Always test your cleaning solution in an inconspicuous area prior to cleaning the entire hardware surface. Wipe surfaces clean using a soft dampened cloth or sponge and rinse completely with warm water immediately after applying the cleaning solution. Use only small amounts of liquid, gentle cleaner. Never use abrasive products, sponges, or wire scrub brushes while cleaning hardware.

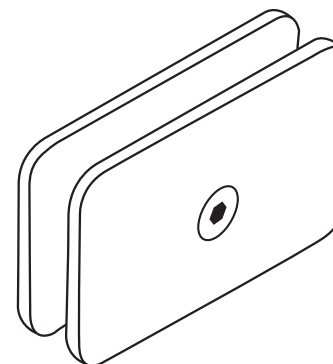

Rear View

HEAVY-DUTY RADIUS CORNERS GLASS CLAMP

180° No Glass Fabrication Square Profile
ITEM NO. CSN180

DO NOT MEASURE / SCALE DRAWING
USE DIMENSIONS SHOWN



Cutout No. SD30

TEMPLATE OPTION
SQUARE CUT GLASS

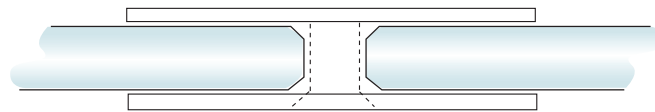

Mounting stud will fit between glass panels. →

← 7/16" (11.11 mm)

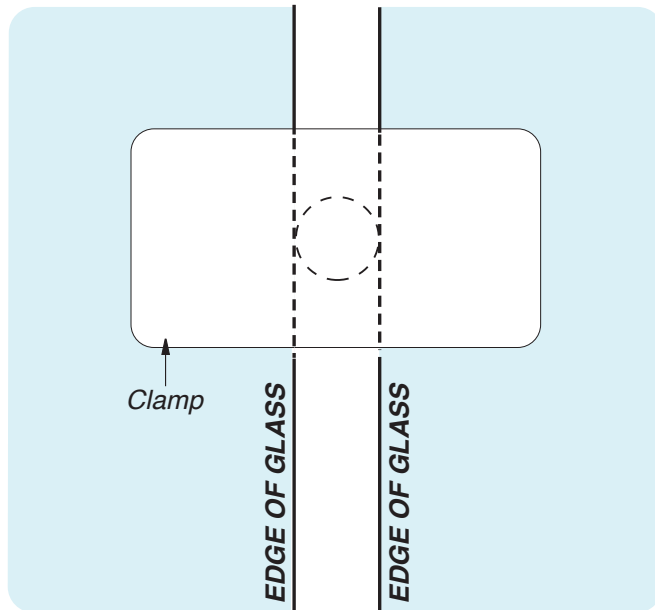

IMPORTANT:
Measure from Finished Edge of Glass

TEMPLATE OPTION
FOR NOTCHED GLASS

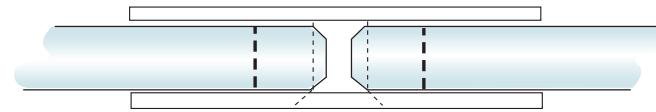

← 1/8" (3 mm)

3/4" (19 mm)
Diameter Hole

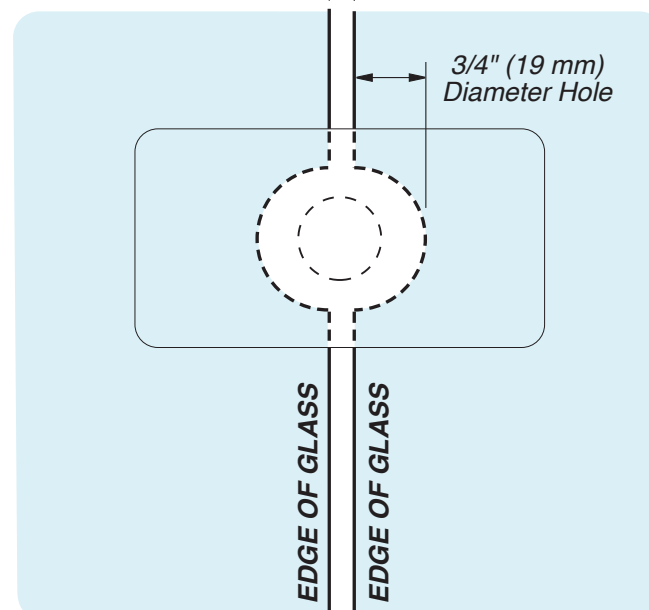

IMPORTANT:
Measure from Finished Edge of Glass



USE ONLY
MONOLITHIC
TEMPERED GLASS



For Technical Support
Call Toll Free in the U.S.
(888) 295-4531

FHC[®]
FRAMELESS HARDWARE COMPANY
THE GLAZING SUPPLY COMPANY