

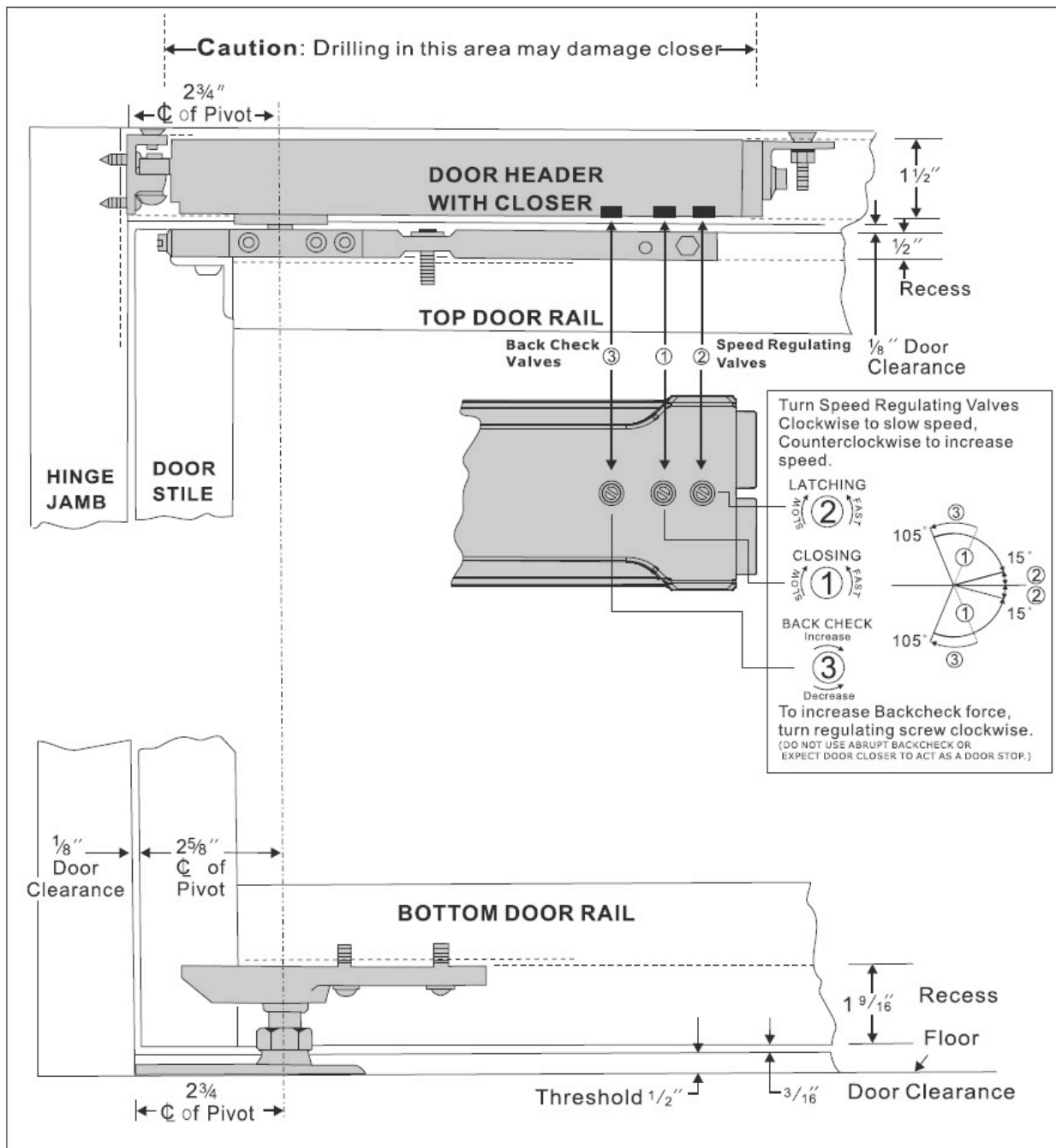

Concealed Overhead
“Competitor”
Series D200
 Center Hung\Double or Single Acting
 Side and End Loading

Installation Instruction



COPYRIGHT 2016 INTERNATIONAL DOOR CLOSERS INC



East: 1920 Air Lane Drive, Nashville, TN 37210 ■ 615/885-7060
West: 4431 E. La Palma, Anaheim, CA 92807 ■ 714/666-0390



Concealed Overhead
“Competitor”
Series D200
 Center Hung\Double or Single Acting
 Side and End Loading

HEADERS & JAMBS

DOOR HEADER

Drill and counter sink outside top surface for 10-32 x $\frac{3}{8}$ " and $\frac{1}{4}$ -20 x $1\frac{1}{4}$ " flat head screws as shown.

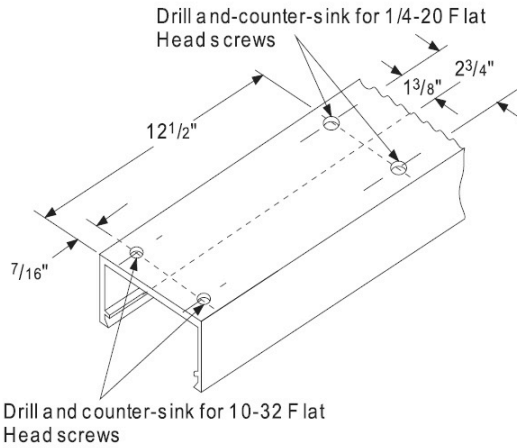

COVER PLATE

Drill $1\frac{3}{4}$ " hole as shown.
 Drill $\frac{1}{2}$ " hole as shown.

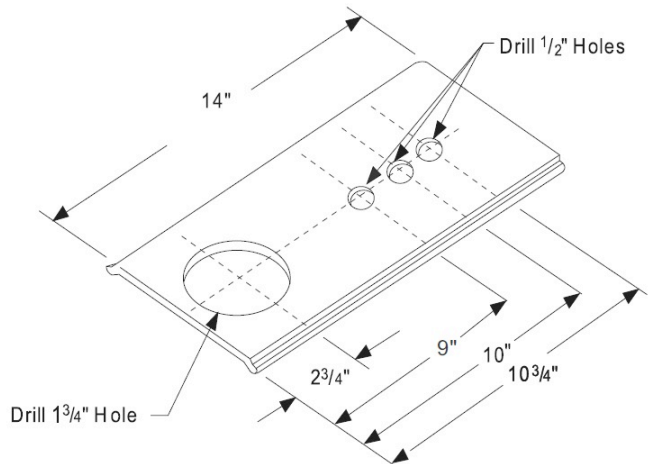

HINGE JAMB

Drill holes for 8-32 x $\frac{1}{2}$ " pan head self-threading screws as shown.

Install anchor using 8-32 x $\frac{1}{2}$ " pan head self-threading screws.

Mount door header on anchor using 10-32 x $\frac{3}{8}$ " flat head self-threading screws/

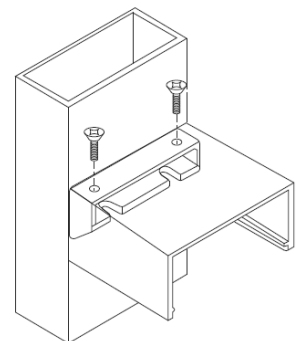
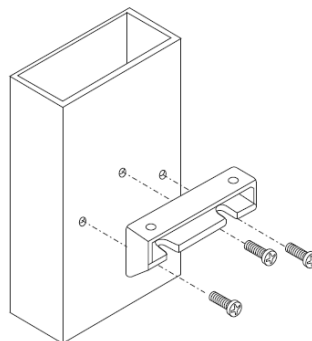
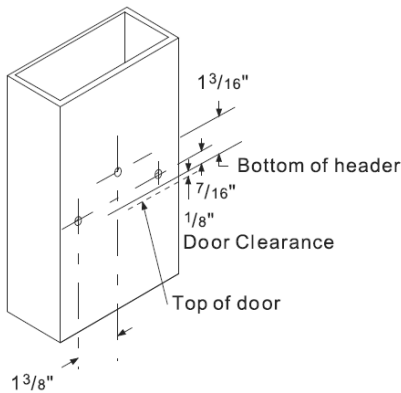

SIDE LOADING

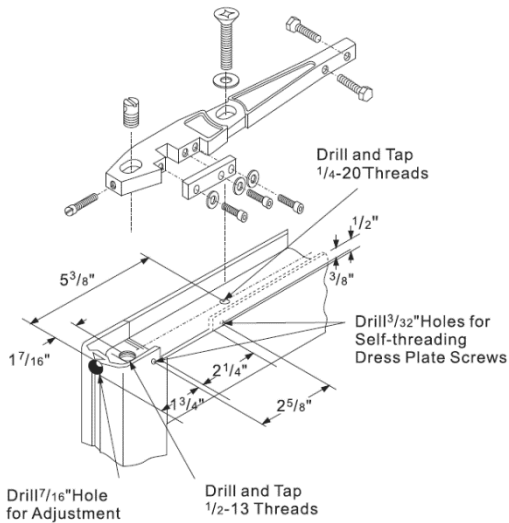

TOP DOOR RAIL "S" Type Side Loading Arm

Drill or drill and tap holes in top of door as shown. Make 2 1/4" x 1/2" cut-out in top of door as shown. Cut-out must be on the inside of the door.

Install arm using 1/4"-20 x 1 1/4" flat head machine screw and 7/8" washer. Install 1/2"-13 x 3/4" arm stud and 1/4"-20 x 1 1/8" dome head arm adjustment screw. Laterally adjust center of the arm spindle retainer 2 5/8" from hinge edge of door (not including weather stripping). Center arm in the top rail by adjusting the two 1/4"-20 x 1" hex head centering bolts. After installation of door, attach dress plate with self-threading screws.

NOTE: Before attaching dress plate, make certain the three 1/4"-20 x 7/8" socket head clamp bar screws with lock washers are tightened securely.

BOTTOM DOOR RAIL Side Loading

Drill and tap 1/4"-20 holes in bottom rail of door as shown. Install pivot bearing retainer in bottom of door using two 1/4"-20 x 5/8" pan head machine screws and lock washers. Laterally adjust center of pivot bearing retainer 2 5/8" from hinge edge of door (not including weather stripping) and tightened screws securely.

THRESHOLD MOUNT PIVOT

Drill hole in threshold as shown. Install threshold adapter nut from top and secure with 3/4"-16 hex jam nut underneath. Install pivot stud and bearing with 1/2"-20 hex lock nut as shown and adjust bearing height for proper door clearance and firmly tighten lock nut.

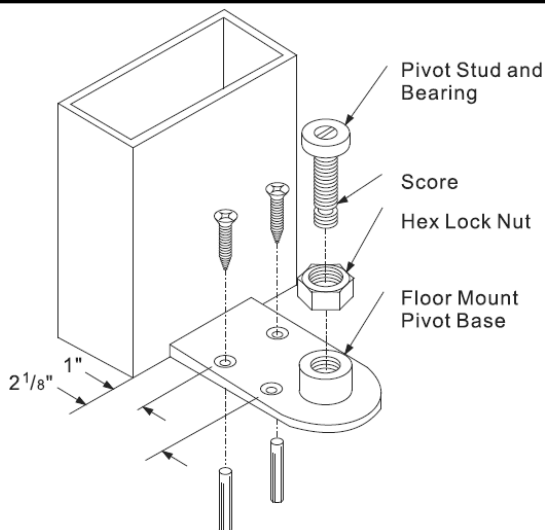
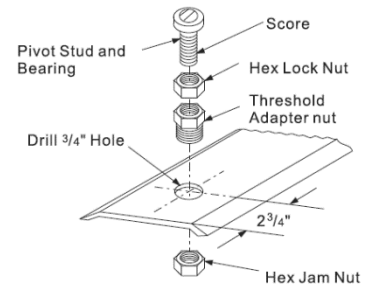
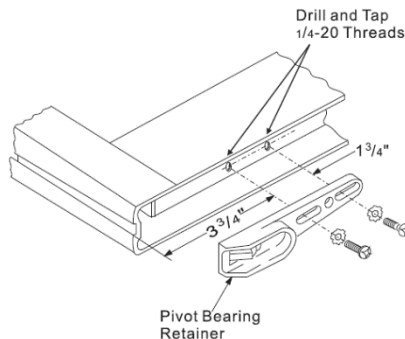

FLOOR MOUNT PIVOT

Center pivot base against door jamb on hinge side. Mark and drill 1/4" holes 1 1/2" deep in floor for plastic expansion plugs. Mount base using #12 x 1 1/4" plastic expansion plugs and #12 x 1 1/4" flat head all-purpose screws.

Install pivot stud and bearing with 1/2"-20 hex lock nut as shown and adjust bearing height for proper door clearance and firmly tighten lock nut. When using threshold, drill 1 1/4" hole for clearance of pivot base on center line 2 3/4" from hinge end of threshold.

NOTE: when threshold is not used, pivot bearing stud must be shortened by sawing off at score 1/2" from bottom

END LOADING

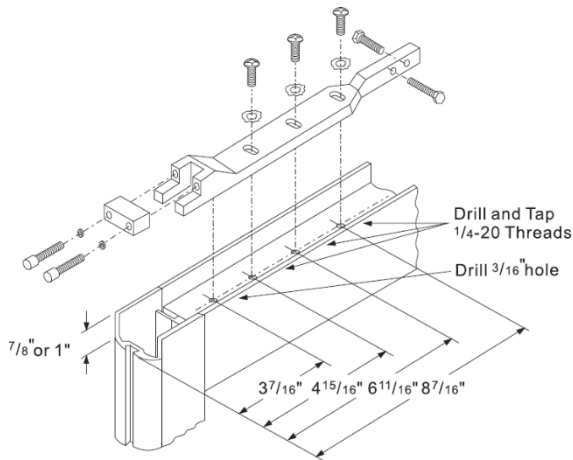

TOP DOOR RAIL

“A” Type Side Loading Arm - Make a 1” deep cut-out in hinge edge of door as shown.

“PT” Type End Loading Arm – Make a 7/8” deep cut-out in hinge edge of door as shown.

Drill or drill and tap holes in top of door as shown.

Position arm in door by placing arm pin in 3/16” hole. Install arm using three 1/4-20 x 5/8” pan head machine screws and lock washers. Center arm in the top rail by adjusting the two 1/4-20 x 1” hex head centering bolts.

NOTE: After door is installed, the two 1/4-20 x 1” socket head clamp bar cap screws with lock washers must be tightened securely..

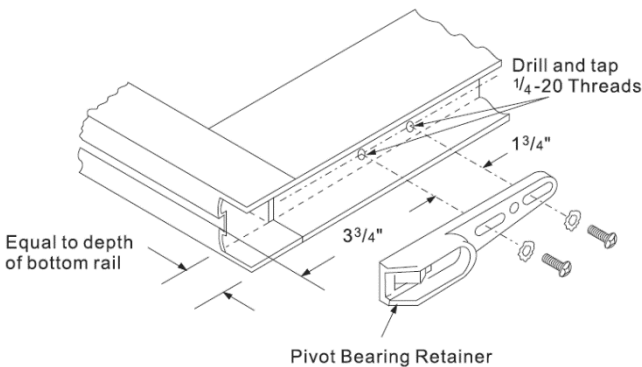

BOTTOM DOOR RAIL

End Loading

Make cut out in hinge edge of door equal to depth of bottom rail as shown.

Drill and tap 1/4-20 holes in bottom rail of door as shown.

Install pivot bearing retainer in bottom of door using two 1/4-20 x 5/8” pan head machine screws and lock washers.

Laterally adjust center of pivot bearing retainer 2 5/8” from hinge edge of door (not including weather stripping) and tighten screws securely.

NOTE: For doors with 1” bottom rail depth, pivot bearing stud must be shortened by sawing off at score 1/2” from bottom.

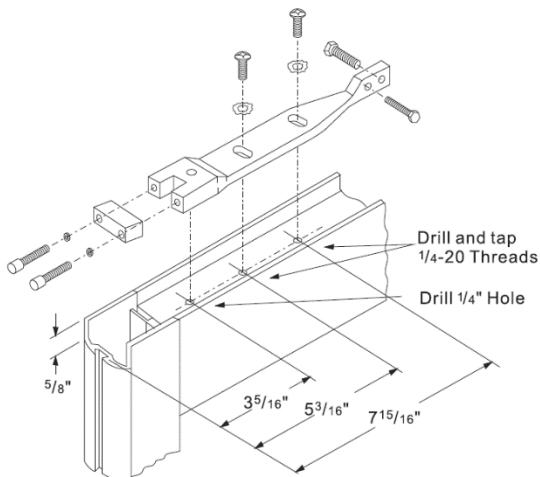

TOP DOOR RAIL

“K” Type End Loading Arm – Make a 5/8” deep cut-out in hinge edge of door as shown.

Drill or drill and tap holes in top of door as shown.

Position arm in door by placing arm pin in 1/4” hole. Install arm by using two 1/4-20 x 5/8” pan head machine screws and lock washers. Center arm in the top rail by adjusting the two 1/4-20 x 1” hex head centering bolts.

NOTE: After door is installed, the two 1/4-20 x 1” socket head clamp bar cap screws with lock washers must be tightened securely.