

Item No. **FHCMS13A & FHCMS13BL**

Installation Instructions

Fabricate the glass using the dimensions below for the cut-out. Dry fit one side to the interior side of the door, and the other side to the outside, making sure that the opening in the mail slot is centered on the glass cut out. Attach with FHC Item No. S450C Clear Silicone on both halves between the plastic and glass door. When applying each bead of silicone, stay within the groove on the plastic frame. Use tape to hold halves in place while silicone cures.

Material Content:

FRAME - High impact plastic assembly with black brush strip and aluminum flap.

FLAPS - Anodized aluminum in satin or black anodized finish.
 Package Includes two halves.
 One Interior and One Exterior Flap.

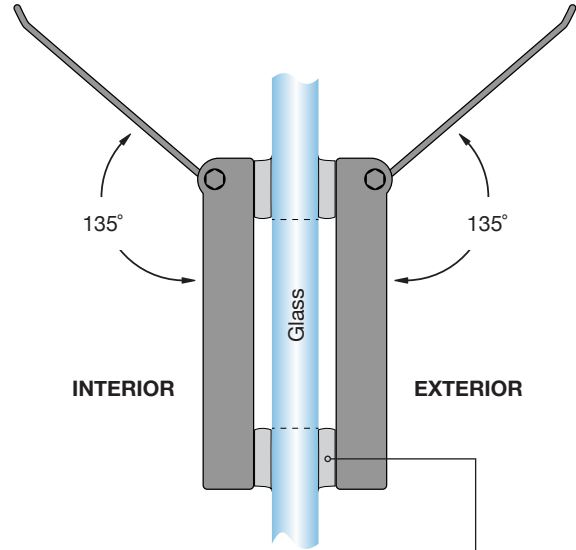

Put a Silicone Bead (Item No. S450C) on All Four Sides of Both Halves of Mail Slots

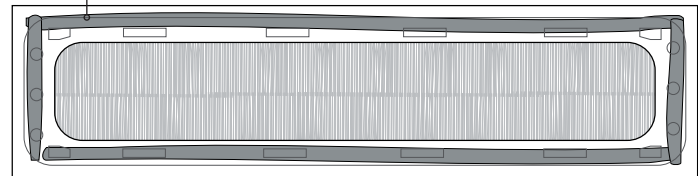

DO NOT MEASURE / SCALE DRAWING
 USE DIMENSIONS SHOWN

