

## INSTALLATION INSTRUCTIONS

# HPE2 & HPE2FS DOUBLE GLASS DOOR ELECTRIC STRIKES

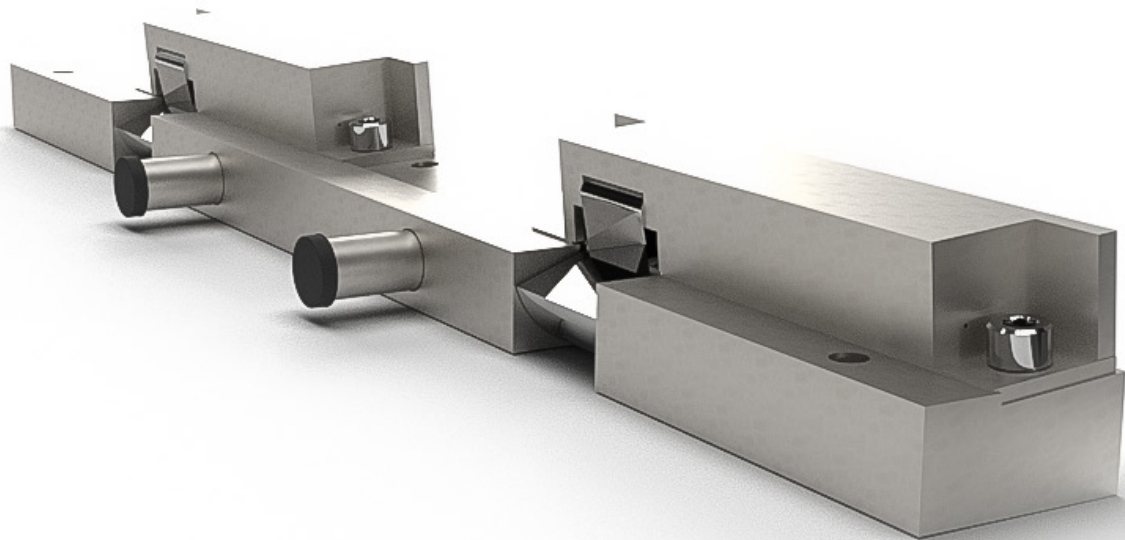

EXPERIENCE AND INNOVATION

## TABLE OF CONTENTS

FEATURES .....	3
Specifications .....	3
Electrical .....	3
COMPATIBILITY/ OVERVIEW.....	4
HPE1 HEADER INSTALLATION .....	5
DOOR ADJUSTMENTS .....	6
Herc Door® Adjustments.....	6
All-Glass Door Adjustments.....	6
PANIC BAR AND STRIKE ADJUSTMENTS .....	7
Strike Bolt Adjustment .....	7
Rubber Bumper Adjustment.....	7
PARTS.....	8

FHC HPE2 with HS3101NFS (Non-Fail-Safe) Installed

FHC HPE2FS with HS3101FS (Fail-Safe) Installed

FHC Folger Adam 310-1 Electric Strike: The HPE2 and HPE2FS is an industrial grade electric strike designed specifically for use in double glass door applications. The stainless steel construction makes it ideal for strength and corrosion resistance.

- Designed for 1/2" or 3/4" Tempered
- Double Glass Doors
- 3/4" Keeper
- 1500 Lb. Static Strength
- Rated for 1 million cycles
- Non-Handed
- 24 VAC
- 3-Hour Fire Rated
- ANSI/BHMA A156.31, Grade 1
- RoHS Compliant
- UL 1034 burglary-resistant listed
- UL294 Listed

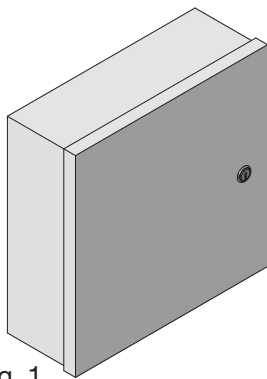

Fig. 1

FHC recommends a dedicated power supply for the electric strike to ensure stable and consistent power delivery.

Fail-Safe or Fail-Secure (Non-Fail-Safe) Power Mode:

If the electric strike is fail-safe, it will unlock when power is lost, which is typically required for fire exits or emergency egress points.

If the strike is fail-secure, it will remain locked when power is lost, which is common for security purposes but may not be allowed in certain fire code scenarios.

The FHC power supply can handle either operating mode.

FHC Low Voltage Power Supply  
#PS632KL 2 Amp

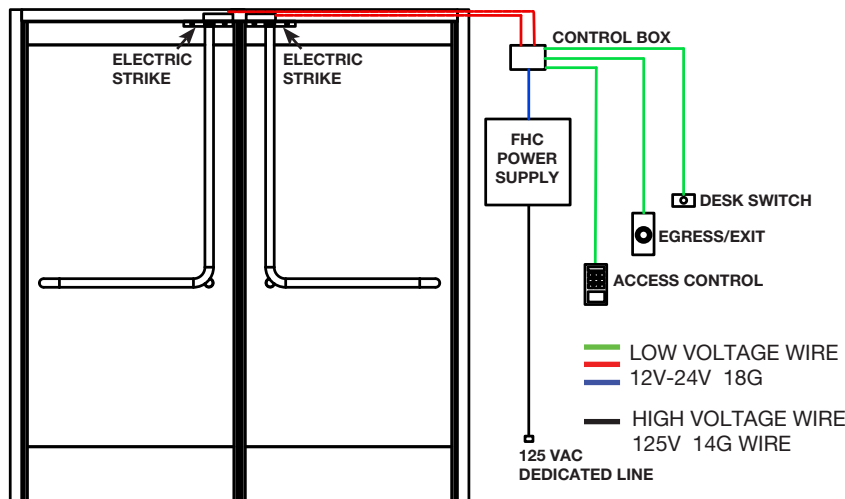

Fig. 2

Double Door Electric Strike  
Controlled Access

The HPE2 and HPE2NFS Electric Strike System requires 24VAC as provided by the FHC Power Supply. As shown in the illustration, several switching options are available with and without the Fail-Safe feature. See literature included with supply and controls for more wiring details.

NOTE: Local codes always prevail over manufacture's electrical connection guidelines. Check requirements carefully before installing power and switching components.

## COMPATIBILITY OVERVIEW

### HPE2 Double Door Electric Strike

An initial site survey should verify the following door and header configurations:

- Door Type Requirement- HPE2 series electric strikes are designed to be used with HP100 Series Steincraft Panic Handles mounted to tempered single-glass doors, and/or Herc-Doors®.
- Header Style- Hollow aluminum, steel, or solid material that can be mortised for the strike solenoid.

#### FHC HPE2 Electric Strike for Double Doors

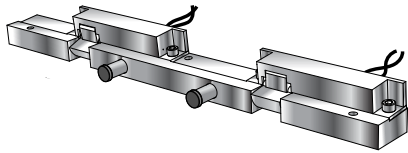

FHC HPE2 Electric Strikes are compatible with both Herc-Door® Rails and Frameless Glass Entrances with the Steincraft Panic Handle as shown in this illustration.

Fig. 3

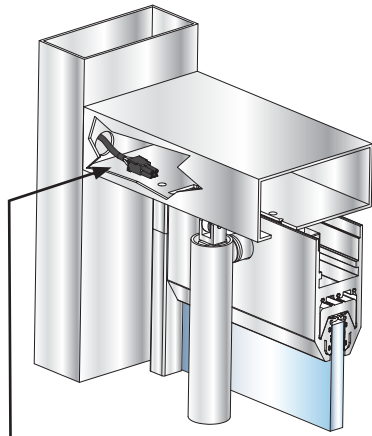

**FHC recommends pre-wiring the header in the early stages of the project (See Figure 2).**

Fig. 4

#### Compatible Doors with HPE2 Electric Strikes

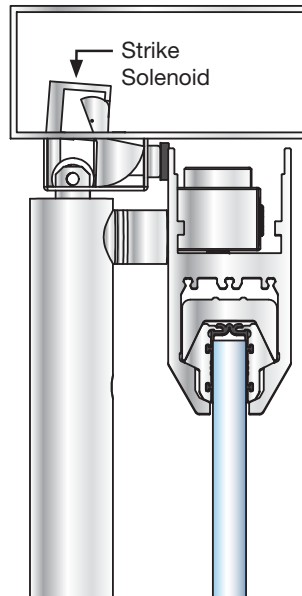
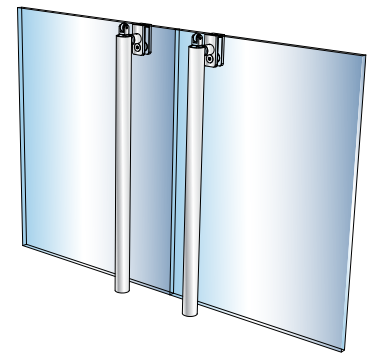
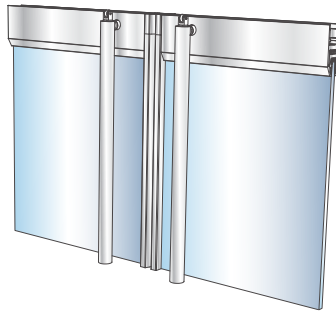

**Herc Doors® with HP100 Steincraft Panic Handle**

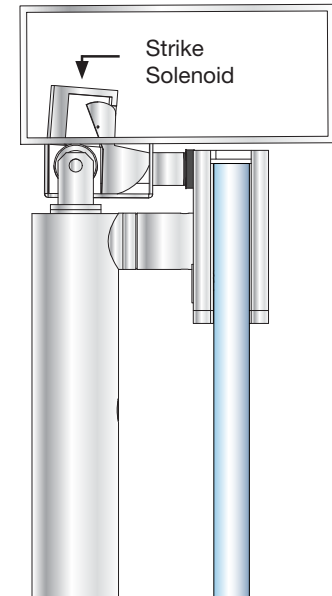

**Glass-Mounted HP100 Steincraft Panic Handle**

#### Header Requirement:

The door frame header must allow a hollow area, or other type of concealed space, for the HPE2 electric strike solenoid and electrical wiring.

Fig. 5

# HPE2 AND HPE2FS ELECTRICAL STRIKE INSTALLATION

## HPE2 Header Cut-Out Details

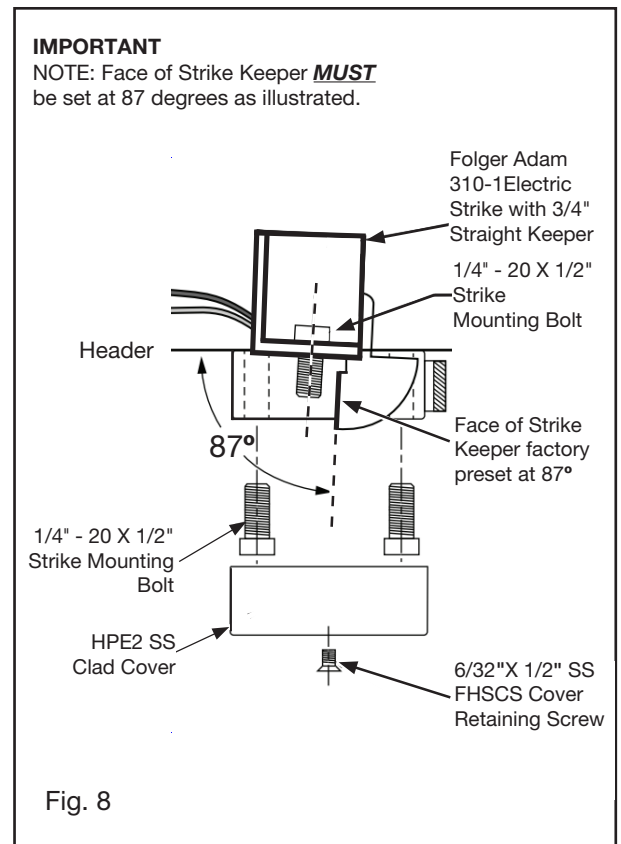
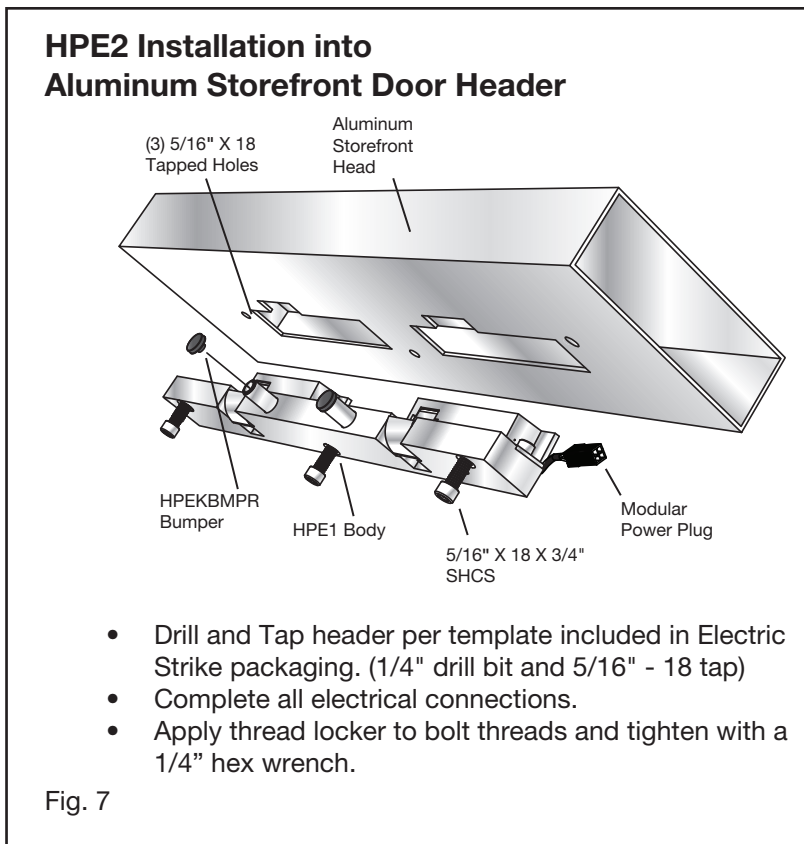
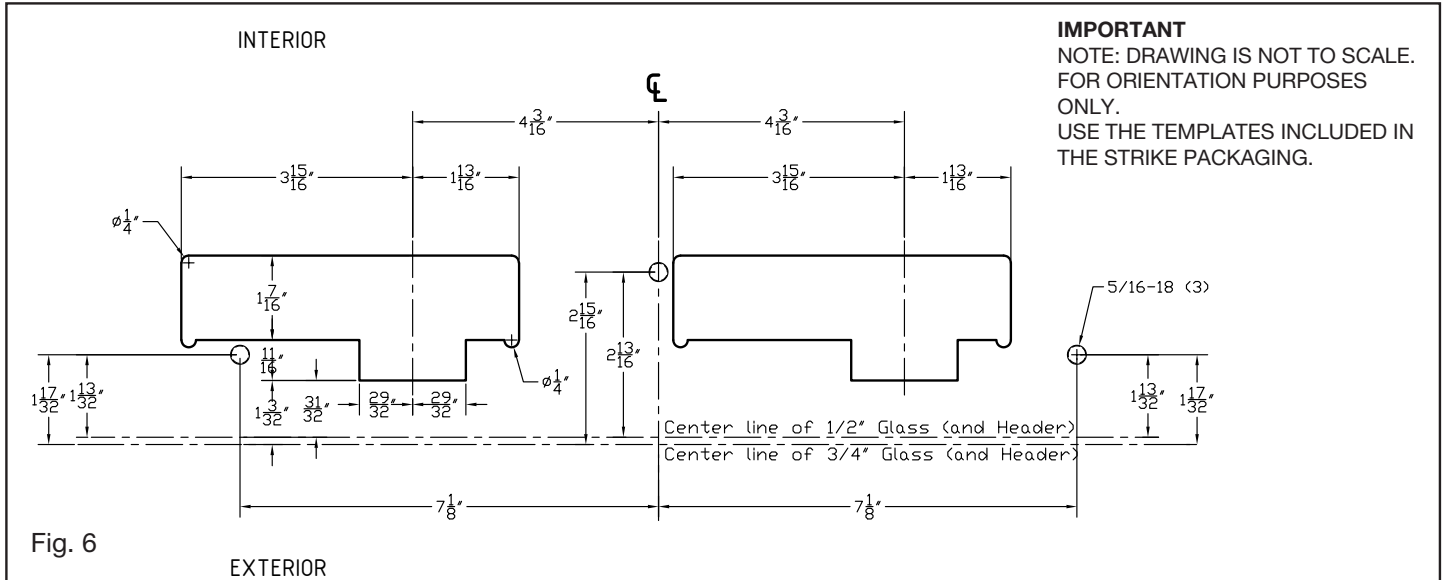

## DOUBLE HPE2 AND HPE2FS DOOR ADJUSTMENTS

### Adjust Door Swing Center

Verify that the door, or pair of doors, are centered by the closer or operator when in the closed position (Figure 9).

Adjustments to concealed overhead closers, offset surface-mount closers, floor closers, and electric operators may be required. Most closers have centering adjustments. See manufacturer's literature for specific centering procedures.

Adjust if necessary.

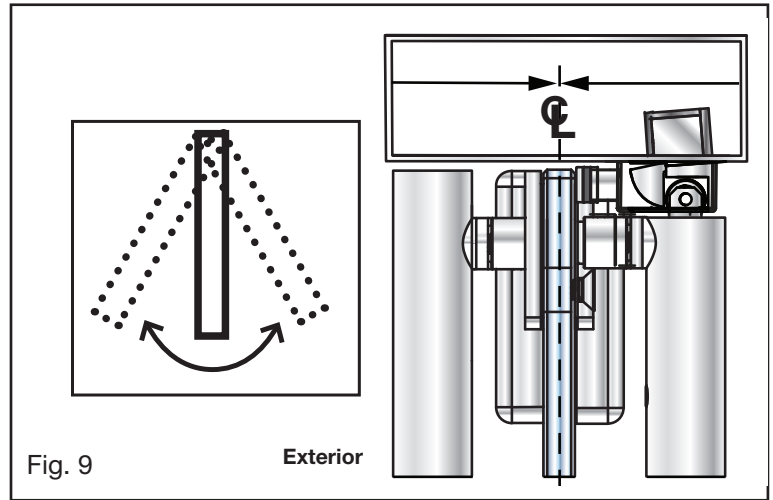

Fig. 9

Exterior

### Adjust Panic Handle Offset

A 2" separation or offset between the interior panic handle and the glass surface is required for proper strike alignment. Adjustments may be made to the top pivot connector by turning the threaded collar, thereby increasing or decreasing the vertical panic bar offset. Adjustment can be made to all Steincraft 100 Panic Bar assemblies. To make adjustments to glass-mounted panic handles, simply add shims to the top connector base plate or adjust the bottom pivot. Refer to the FHC HP100 Steincraft panic handle installation manual for more information (Figure 10).

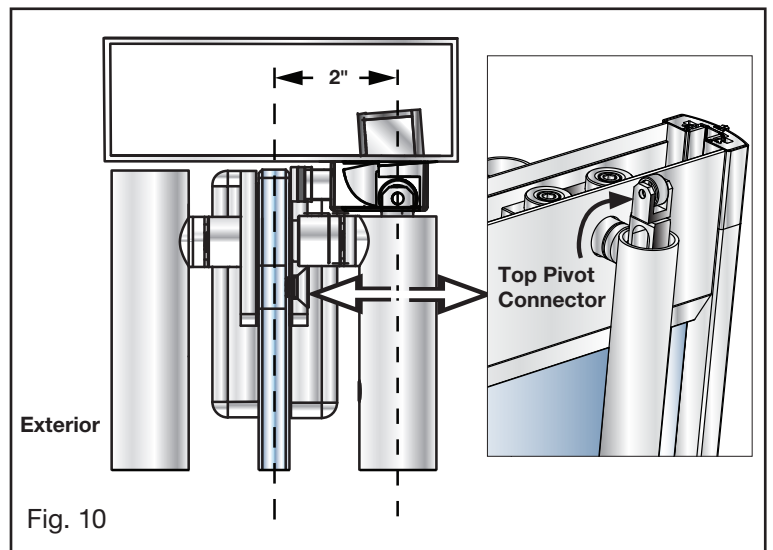

Fig. 10

Exterior

### Adjust Top Door Gaps

The top door gap should be between 1/8" and 3/16" to prevent frame binding and allow for optimum electric strike engagement. The door frame gap can be adjusted by the hinge mounts. The Steincraft Panic Handles have adjustment features built into the pivot points and various size actuator bushings. Refer to the FHC HP100 Steincraft Panic Handle installation manuals for details (Figure 11).

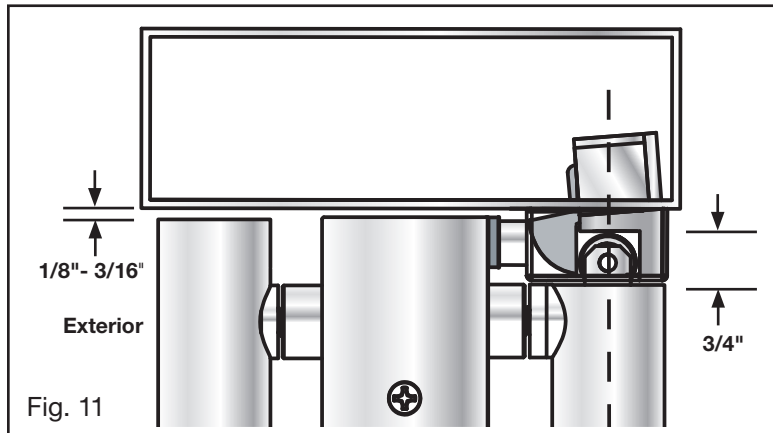

Fig. 11

Exterior

EXPERIENCE AND INNOVATION

**FHC**  
FRAMELESS HARDWARE COMPANY

## HPE2 AND HPE2FS PANIC BAR / STOP ADJUSTMENTS

### Bolt Adjustment

The Retractable Bolts may require adjusting, either up or down, in order to properly engage the strike. The centerline of the roller should penetrate the strike by at least 1/8". The maximum adjustment is 3/4" above the top of each vertical panic tube (Figure 12). Loosen the flathead retaining screw located just below the top connecting bolt of the panic handle. **A**

Do not remove.

Rotate the bolt 360 degrees in either direction to extend or retract. **B**

After adjusting, tighten the flathead screw. Verify that the retractable bolt engages the strike within the 3/4" maximum extension range.

Open and close the door several times.

The bolt should compress into the handle by deflecting off of the curved strike when closing the door. The bolt should retract when opening the door with the panic handle.

When the strike is fail-safe, the door can only open from the inside panic handle or when the strike is energized.

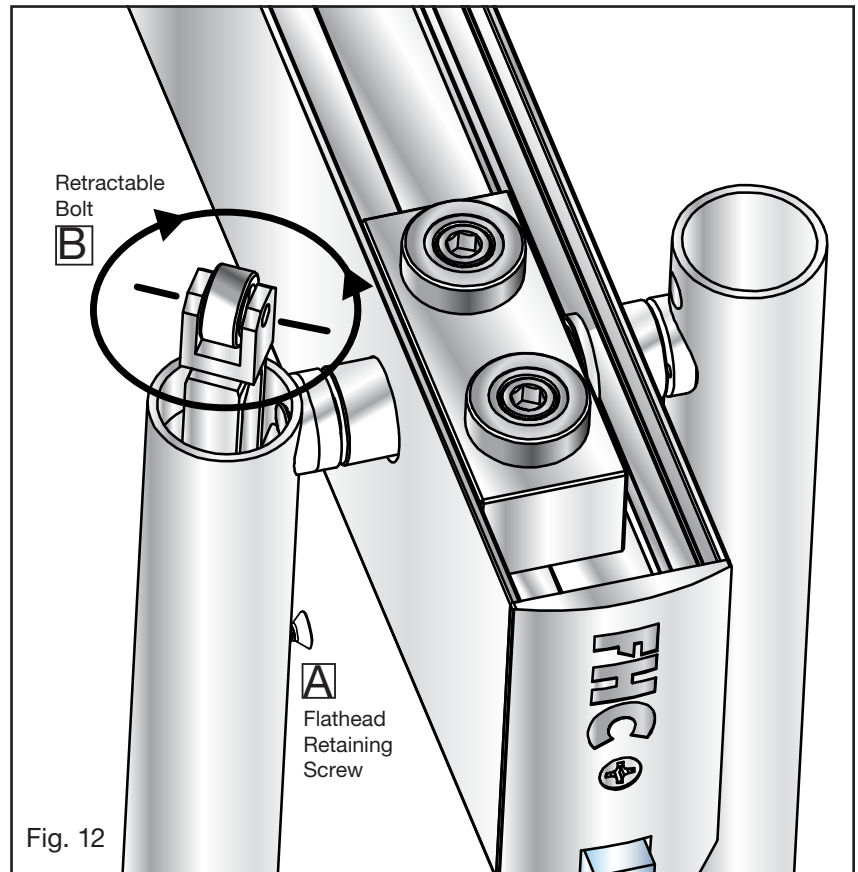

Fig. 12

### Bumper Adjustment

Install the cover before adjusting.

Remove the rubber stops and turn the bumper keepers with a 1/4" hex key wrench (Figure 13).

The door should be held firmly by the stops without rattling.

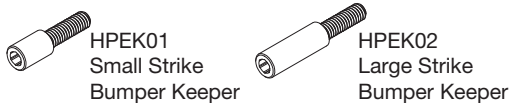

It may be necessary to switch bumper keeper bolts in order to bring the door into correct adjustment. Remove and replace using the 1/4" hex wrench.

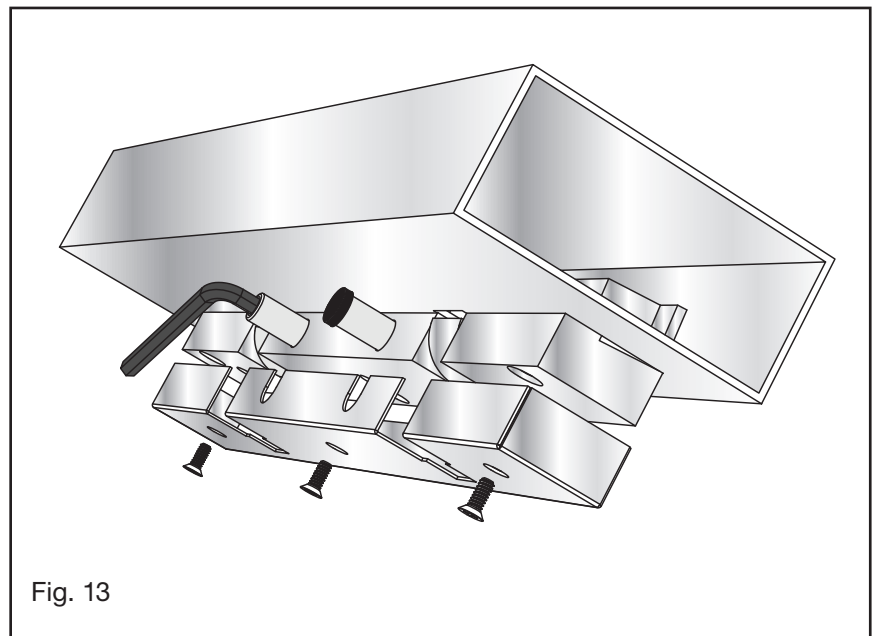
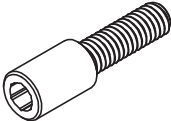
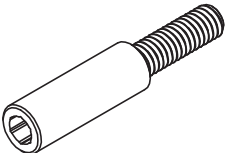



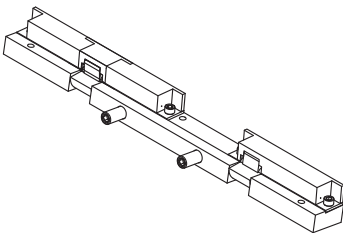
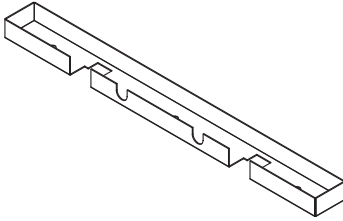

Fig. 13

# PARTS

## PARTS LIST

QTY	PART IMAGE	PART NUMBER	DESCRIPTION
2		HPEK01	SMALL STRIKE BUMPER KEEPER
2		HPEK02	LARGE STRIKE BUMPER KEEPER
2		FLAT-HEAD SHCS	6/32"X 1/2" SS FHSCS
2		5/16"-18 X 3/4" SS SHCS	5/16"-18 X 3/4" SS SHCS
2		1/4"-20 X 1/2" SS SHCS	1/4"-20 X 1/2" SS SHCS
2		HPEKBMPR	RUBBER BUMPER
1		HPE2BODY	HPE2 ALUMINUM BODY
1		EPE2BSC-PSC	HPE2 SS CLAD COVER