

MODEL SUI SERIES

ROUGH OPENING: 24"-3/8 (w) x 48-3/8" (h)

SERVICE OPENING: 20" (w) x 17-3/4" (h)

SUI100 INTERIOR VIEW

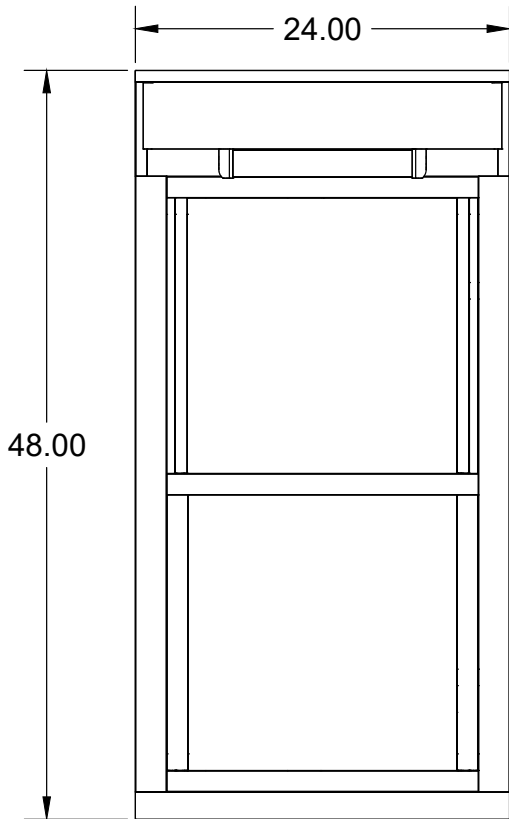

SUI100 EXTERIOR VIEW

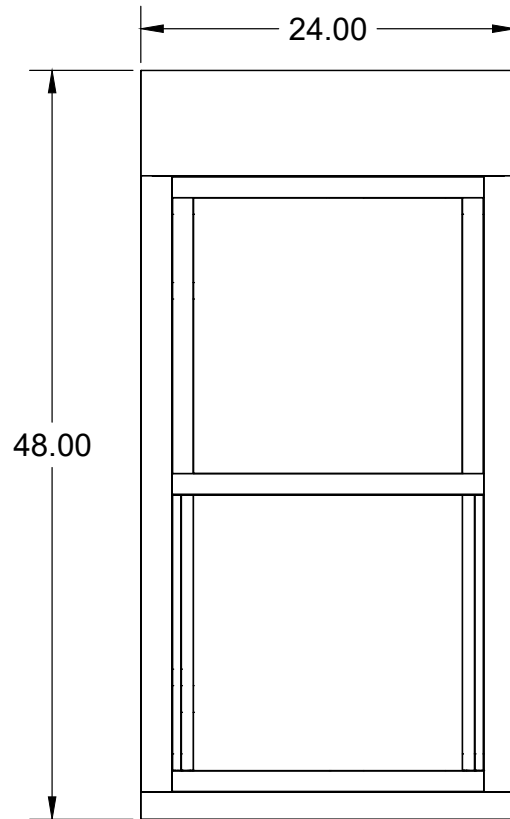

SUI100 SIDE VIEW

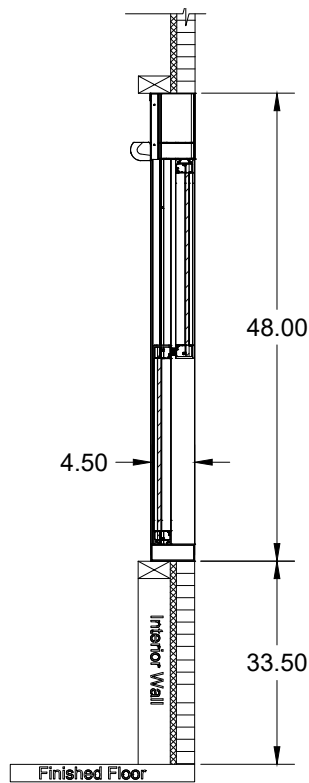

ALL QUIKSERV PRODUCTS ARE SHIPPED FULLY-ASSEMBLED and READY TO INSTALL. EACH ELECTRICAL UNIT IS SHIPPED WITH A FOUR FOOT (4') BX DROP.

SUI SERIES

SUI 100-1 AUTOMATIC

DIMENSIONS	WIDTH	HEIGHT
OVERALL	24"	48"
ROUGH OPENING	24-3/8"	48-3/8"
SERVICE OPENING 100	20"	18"
SERVICE OPENING 200		

Standard Finish	Clear Anodized	Dark Bronze Anodized
Custom Finish		
Framing	Standard Aluminum	
Standard Glass	1/4" Tempered	

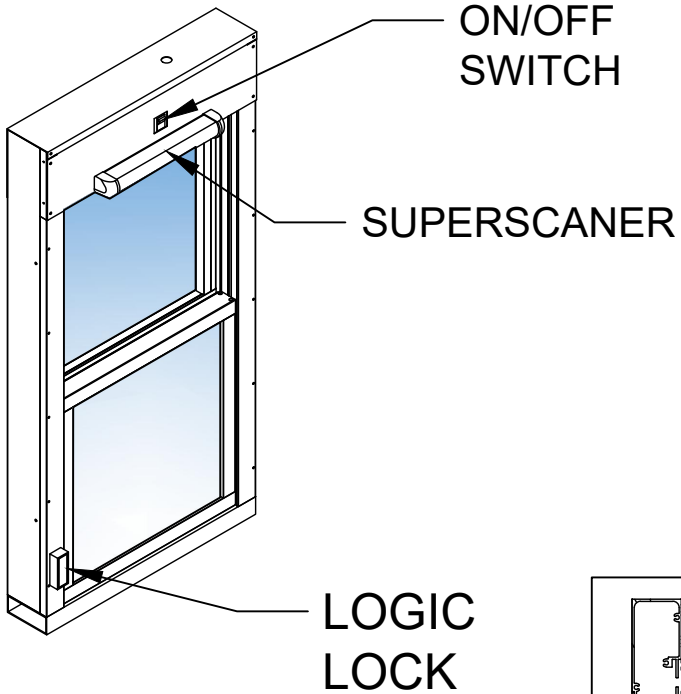

SIDE SECTION

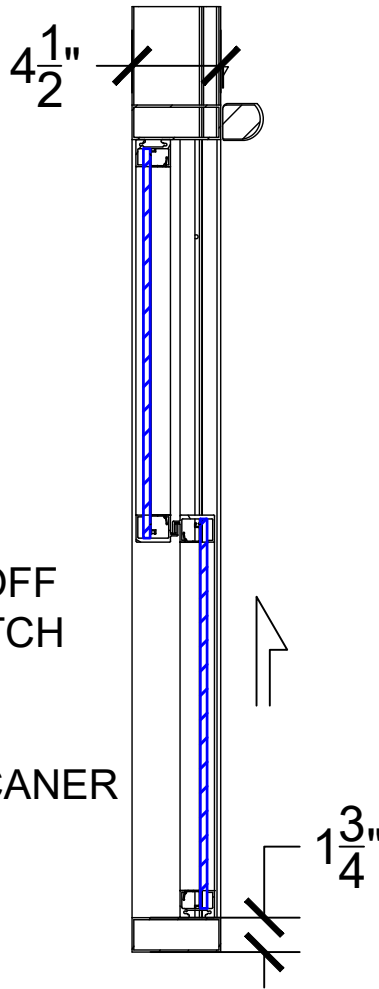

INTERIOR SECTION

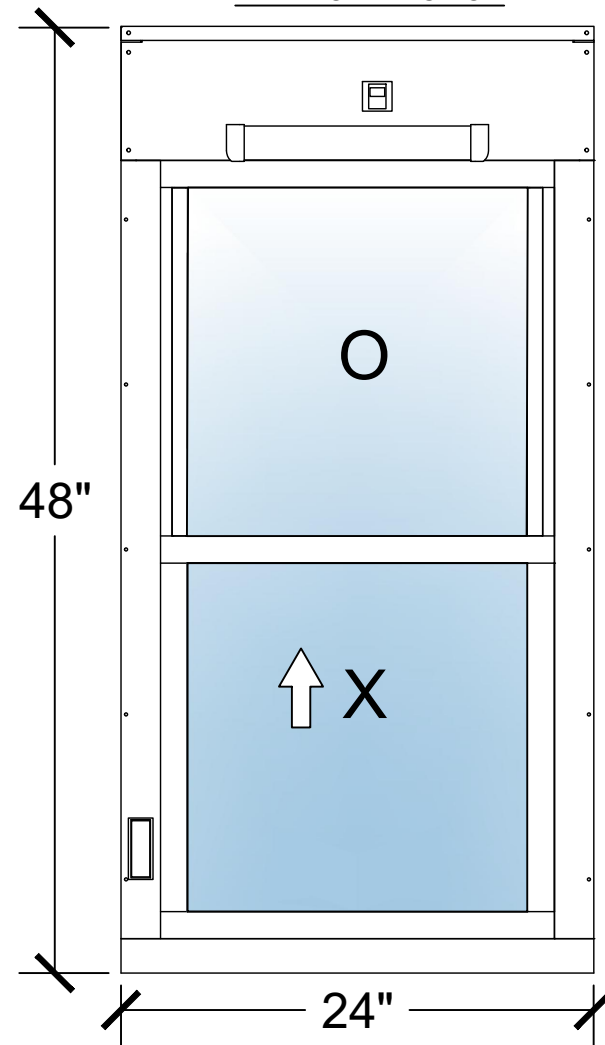

TOP SECTION

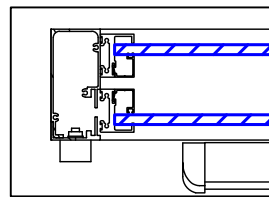
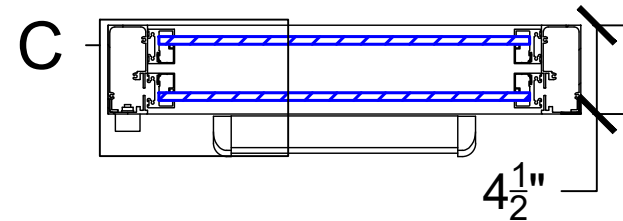

NOTE: THIS DRAWING EMBODIES A CONFIDENTIAL DESIGN ORIGINATED AND OWNED BY QUIKSERV CORP., AND IS SUBMITTED UNDER CONFIDENTIAL RELATION. ALL PATENT, MANUFACTURING, AND SALE RIGHTS ARE RESERVED EXCEPT TO THE EXTENT RIGHTS THAT ARE EXPRESSLY GRANTED TO OTHERS. THE RECIPIENT AGREES BY ACCEPTING THESE DRAWINGS NOT TO SUPPLY OR DISCLOSE ANY INFORMATION TO ANY UNAUTHORIZED PERSONNEL.



SUI-100 ELECTRIC

FILE NAME	SUI 100-1.dwg	DRAWN BY:	Avasquez	REV
DRAWN	3/25/2020	SCALE:	1:0.9746	---

No changes can be made after product goes into production.
 If ordering windows, check all dimensions and slide direction.
 Proceed Proceed with change Note changes and Resend

Signed _____ Date Signed _____