

**NOTE: DOOR OPENINGS TO 120° - CONDITIONS PERMITTING.**

1. Adjust spring power to match door width as indicated by chart on front page.
2. Mount closer on door as dimensions shown. Tube end toward hinge. If pivots are used, locate closer and shoe from CENTERLINE OF PIVOT.  
(For offset pivots, increase the marked dimensions by 1/8" (3 mm))
3. Place main arm on top of shaft, 100° to closer body, insert arm screw into top of shaft and tighten.
4. Attach shoe to frame as shown. (If more latching power is required, rotate shoe 180°.)
5. Open door and insert rod in forearm.
6. With forearm at right angle to door (90°), insert forearm set screw and tighten. (IF HOLD OPEN ARM IS USED, THE NUT IS ON THE TOP FOR RH DOOR AND BOTTOM FOR LH DOOR)

**REGULATION**

A "Normal" closing time from 90° open position to door stop position is 4 to 6 secs, evenly divided between main swing speed and latch swing speed. Use hex key (furnished) to adjust speed. To slow main speed of door, turn regulating valve nearest shaft clockwise. To slow latch speed, turn regulating valve nearest hinge clockwise.

**BACKCHECK**

To increase backcheck force, turn regulating valve nearest hinge clockwise. DO NOT USE ABRUPT BACKCHECK OR ALLOW DOOR CLOSER TO ACT AS A DOOR STOP.

**COVER**

Place insert in proper cutout, then push over against door frame. Tighten both cover screws securely.

**HOLD OPEN ADJUSTMENT ( When hold open arm is used)**

Loosen adjusting nut, open door to desired hold open position tighten nut. Do not permit door to swing while hold open is set.

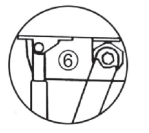
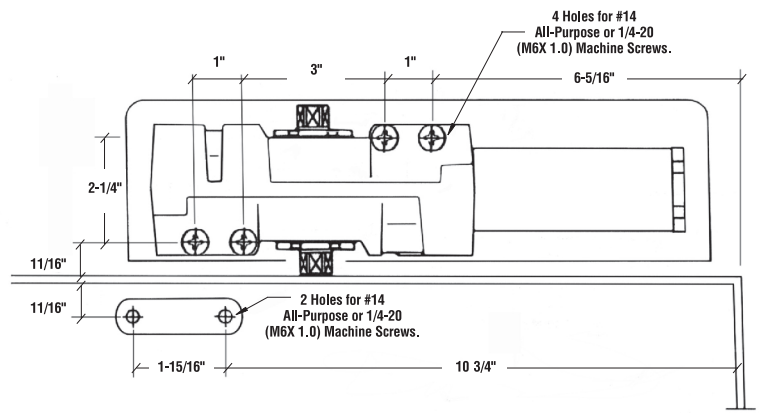
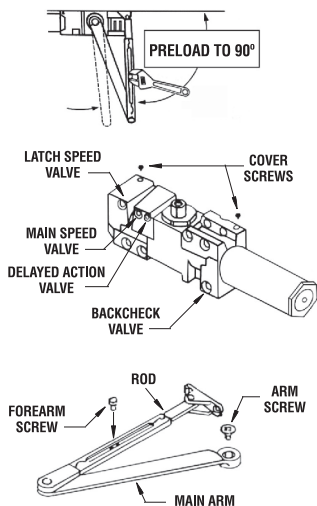

**NOTE: DOOR OPENINGS TO 120° - CONDITIONS PERMITTING.**

1. Adjust spring power to match door width as indicated by chart on front page.
2. Mount closer on door as dimensions shown. Tube end toward hinge. If pivots are used, locate closer and shoe from CENTERLINE OF PIVOT.  
(For offset pivots, increase the marked dimensions by 1/8" (3 mm))
3. Place main arm on top of shaft, 100° to closer body, insert arm screw into top of shaft and tighten.
4. Attach shoe to frame as shown. (If more latching power is required, rotate shoe 180°.)
5. Open door and insert rod in forearm.  
Use optional Extended Arm Rod No. SM90XTA
6. With forearm at right angle to door (90°), insert forearm set screw and tighten. (IF HOLD OPEN ARM IS USED, THE NUT IS ON THE TOP FOR RH DOOR AND BOTTOM FOR LH DOOR)

**REGULATION**

A "Normal" closing time from 90° open position to door stop position is 4 to 6 secs, evenly divided between main swing speed and latch swing speed. Use hex key (furnished) to adjust speed. To slow main speed of door, turn regulating valve nearest shaft clockwise. To slow latch speed, turn regulating valve nearest hinge clockwise.

**BACKCHECK**

To increase backcheck force, turn regulating valve nearest hinge clockwise. DO NOT USE ABRUPT BACKCHECK OR ALLOW DOOR CLOSER TO ACT AS A DOOR STOP.

**COVER**

Place insert in proper cutout, then push over against door frame. Tighten both cover screws securely.

**HOLD OPEN ADJUSTMENT ( When hold open arm is used)**

Loosen adjusting nut, open door to desired hold open position tighten nut. Do not permit door to swing while hold open is set.

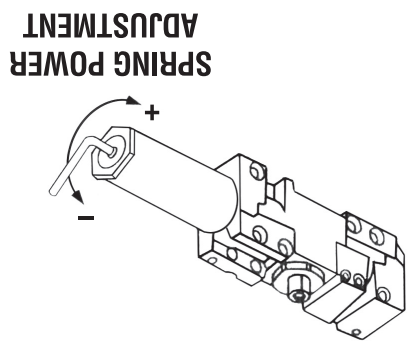
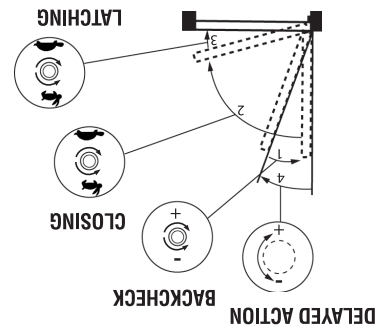
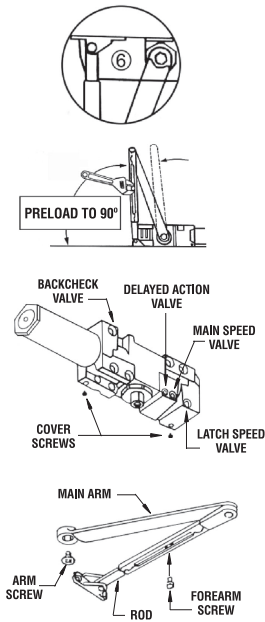

FULL TURNS REQUIRED	MAXIMUM DOOR WIDTH	
	EXTERIOR DOORS	INTERIOR DOORS
5 TURNS	5 LB-BF	8.5 LB-BF
2 TURNS	3.4"	3.8"
FACTORY SET	4.8"	5.4"
5 TURNS	4.8"	3.6"
10 TURNS	5.4"	4.2"
15 TURNS	6.0"	4.8"

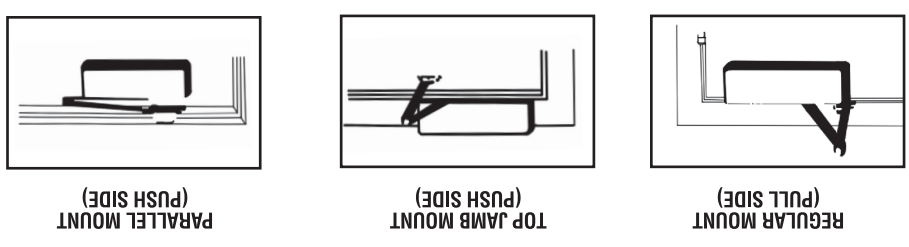

1. Before installation, (parallel arm), turn Backcheck selector valve (found on the opposite side of closer) ALL THE WAY IN (CLOCKWISE).

2. Adjust spring power to match door width as indicated by chart on front page.

3. Mount closer on door as dimensions shown. Tube end toward latch. If pivots are used, locate closer and parallel bracket from CENTERLINE OF PIVOT.

4. Place open end wrench on bottom shaft and turn toward hinge jamb about 30° and then place main arm on top of shaft, insert arm screw into top of shaft and tighten.

5. Attach parallel bracket on frame as dimensions shown.

6. Attach parallel rod and shoe to parallel bracket as shown.

7. Insert rod in forearm, and then insert main arm to closer parallel to door. Then insert forearm set screw and tighten. (IF HOLD OPEN ARM IS USED, THE NUT IS ON THE TOP FOR RH DOOR AND BOTTOM FOR LH DOOR)

**REGULATION**  
A "Normal" closing time from 90° open position to door stop position is 4 to 6 secs, evenly divided between main swing speed and latch swing speed. Use hex key (furnished) to adjust speed. To slow main speed of door, turn regulating valve nearest shaft clockwise. To slow latch speed, turn regulating valve nearest hinge clockwise.

**BACKCHECK**  
To increase backcheck force, turn regulating valve nearest hinge clockwise. DO NOT USE ABRUPT BACKCHECK OR ALLOW DOOR CLOSER TO ACT AS A DOOR STOP.

**COVER**  
Place insert in proper cutout, then push over against door frame. Tighten both cover screws securely.

**HOLD OPEN ADJUSTMENT ( When hold open arm is used)**  
Loosen adjusting nut, open door to desired hold open position tighten nut. Do not permit door to swing while hold open is set.

**NOTE: DOOR OPENINGS TO 180° - CONDITIONS PERMITTING.**

