



Steincraft® 8800 Series Display Case



CAUTION:

FAILURE TO COMPLY WITH FRAMELESS HARDWARE COMPANY'S INSTRUCTION SHEET WILL VOID ANY WARRANTIES.

THE TOP AND BOTTOM RAILS MUST NEVER BE GRABBED, CLAMPED, OR PULLED DURING THE INSTALLATION.

AS WITH ANY TEMPERED GLASS DOOR, INSTALLATION MUST BE COMPLETED USING SUCTION CUPS OR LEATHER GLOVES TO SUPPORT THE GLASS. IN OTHER WORDS, THE TOP AND BOTTOM RAILS ARE NOT INTENDED TO SERVE AS HANDLES TO CARRY AND LIFT THE DOOR INTO PLACE.



IMPORTANT NOTE:

THESE INSTRUCTIONS SHOULD BE USED IN CONJUNCTION WITH FRAMELESS HARDWARE COMPANY'S SHOP DRAWINGS (WHEN APPLICABLE). DOOR OPENINGS AND TOLERANCES MUST BE ADHERED TO IN ORDER FOR STEINCRAFT® 8800 SERIES DISPLAY CASE TO FUNCTION PROPERLY.

STEP 1

Accurately locate and mount SC86150TP Top Pivot with screws provided at the center of adjustment slot.

STEP 2

Use Plumb Bob from SC86150TP Top Pivot to align SC86150BP Bottom Pivot (see **Figure A**). Securely mount SC86150BP Bottom Pivot Receptacles with screws provided at the center of adjustment slot.

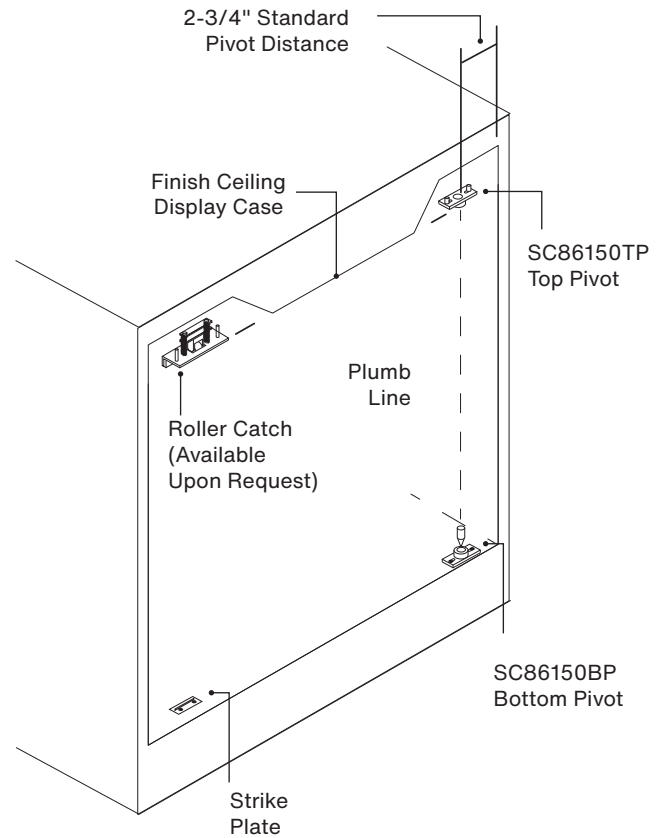

Figure A



American Manufacturing



USE ONLY MONOLITHIC TEMPERED GLASS

STEP 3

Remove SC86150TP Top Pivot and place on display door top pivot pin (see **Figure B**).

STEP 4

Lift the display door and set the bottom mushroom pivot on SC86150BP Bottom Pivot Receptacle and tilt door into opening (see **Figure C**).

STEP 5

Swing the door in the 90 degree open position to gain access to the AP-150 Top Pivot mounting holes (see **Figure D**).

STEP 6

Reinstall SC86150TP Top Pivot with screws provided at center of adjustment slot.

STEP 7

Align door gaps to adjacent door/sidelite by loosening the pivot receptacle mounting screws and moving door too the desired location, re-tighten mounting screws.

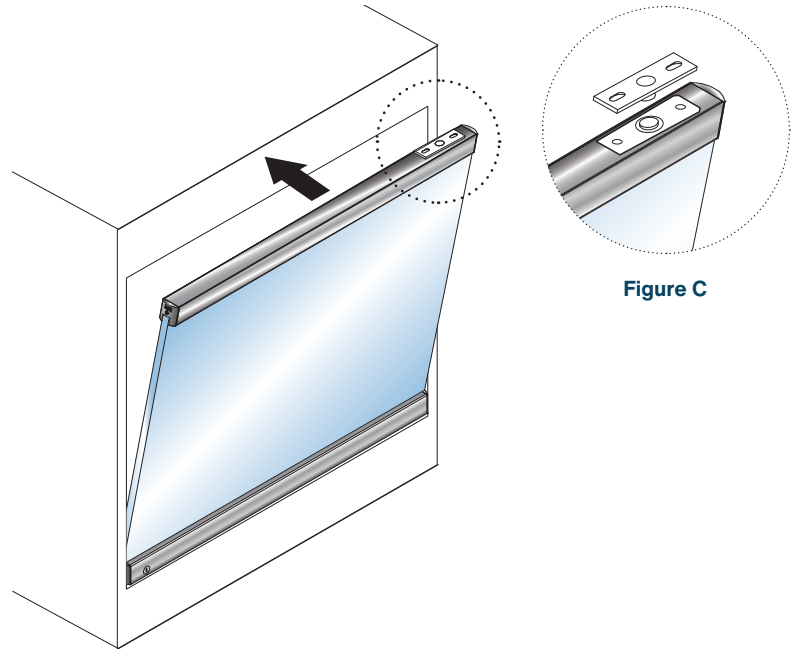

Figure B

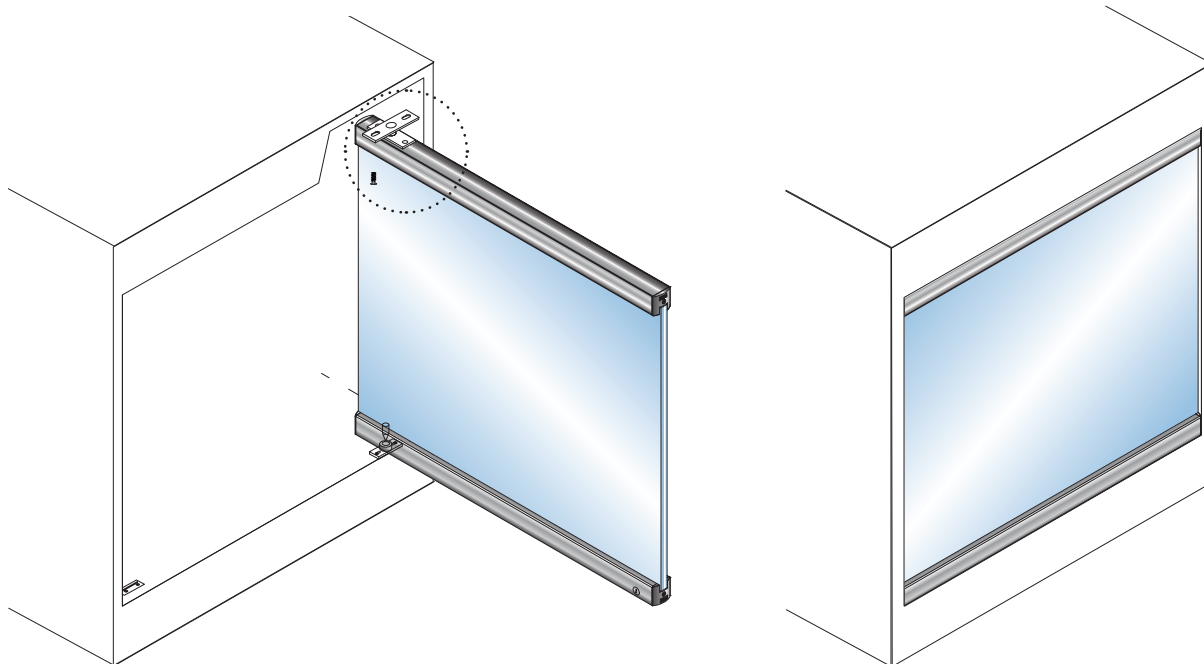

Figure D

Finished Installation

Steincraft® 8800 System Details

